



DeKtec

Catalogue 2022 - 2023

Introduction

Enabling PCs for Broadcast	03
A Short History	03
Organisation	04
What's New in 2022	04

PCI Express

DTA-2107 – Satellite Modulator	05
DTA-2110 – 10GbE SFP+ NIC	06
DTA-2111 – VHF/UHF Modulator	07
DTA-2115B – All-Standard, All-Band Modulator	08
DTA-2116 – All-Standard 0-3GHz Modulator	09
DTA-2127 – Dual DVB-S2X Satellite Receiver	10
DTA-2131 – SDR VHF/UHF Receiver	11
DTA-2132 – High-End Satellite Receiver	12
DTA-2138B – DVB-T2/C2/ISDB-T Receiver	13
DTA-2139C – 12-channel Cable/Terrestrial Receiver	14
DTA-2144B – Quad ASI	15
DTA-2145 – Dual ASI	16
DTA-2160 – Triple ASI, GigE	17
DTA-2162 – Dual GigE	18
DTA-2172 – Dual 3G-SDI/ASI Ports	19
DTA-2174B – Quad 3G-SDI/ASI Ports (1x 12G)	20
DTA-2175 – HD-SDI/ASI with Relay Bypass	21
DTA-2178 – Octal 12G-SDI/ASI Ports	22

DTA-2178-ASI – Octal ASI Ports	23
DTA-2179 – Twelve 3G-SDI/ASI Ports	24
DTA-2195 – 12G-SDI In+Out with HDMI 2.0 Port	25

USB-2 Adapters

DTU-215 – VHF/UHF Modulator	26
DTU-236A – 8-VSB/QAM/ASI Probe	27
DTU-238 – DVB-T/T2, DVB-C and ASI Probe	28
DTU-245 – FantASI ASI In + Out	29

USB-3 Adapters

DTU-315 – VHF/UHF/L-band Modulator	30
DTU-331 – Portable SDR Receiver	31
DTU-351 – HD-SDI Input	32

IP Converters

DTE-3100 – IP to ASI	33
DTE-3114 – Quad QAM Modulator	34
DTE-3120 – ASI to IP	35
DTE-RCK1 and DTE-STAND	36
DTM-3200 – IP to/from ASI	37
DTM-3224 – Quad ASI to IP Converter	38
DTM-3237 – DVB-S2 to ASI	39

Applications

StreamXpress®	40
StreamXpert® v2	41
SdEye	42
Atsc3Xpert, T2Xpert, C2Xpert	43
Atsc3Xpress, T2Xpress, C2Xpress	44
TmmXpress	45
MuxXpert	46
Xpect®	47
Xpect® Mosaic	48

Software Development Kits

DTAPI – DekTec SDK	49
DTAPI-TS – Analysis SDK	50
MuxXpert SDK	51

Sales

Distributors	52
Open Pricing	52
OEM	52
Warranty	52

The best way to predict the future
is to invent it.

Alan Kay

Enabling PCs for Broadcast

DekTec designs and manufactures PC add-on cards, USB- and IP devices, and software for the professional digital-television market. Our devices can be used in three ways

1. For Test & Measurement purposes;
2. To build broadcast infrastructure;
3. As OEM component integrated in your product.

We are pleased to see that our products are widely deployed by virtually every company operating in the digital-television field. The future looks bright, with a roadmap loaded with exciting new products.

Sito Dekker



The astonishing advances in PC technology have enabled the creation of real-time applications never thought possible. DekTec supplies the missing pieces to build complete applications in the form of interface adapters to route digital-TV signals in and out of the PC, and optimized software components to perform the signal processing. The economy of scale provided by the PC platform, combined with DekTec's multi-purpose interface devices and software, enable an exceptional price to performance ratio.

It is our mission to provide digital-TV professionals with innovative, best-in-class hardware and software to successfully deploy PCs in digital-television solutions.

A Short History

DekTec was founded in 2000 by Sito Dekker and Maarten Ghijsen, who both learned the trade at Philips Electronics, the pioneer of digital television. In the early years, several PCI bus adapters were brought to the market. In 2004, the first FantASI USB device was introduced, along with the *StreamXpress*[®] playout software and *StreamXpert*[®] transport-stream analyser, quickly evolving into the industry-standard test-and-measurement toolset for digital-TV lab and field work.

Also in 2004, the first test modulator was developed, the DTA-107 satellite modulator for PCI bus. Several modulators followed over the years, until in 2015 the modulator line was

completed with two high-end test modulators, supporting all current cable, terrestrial and satellite standards: The portable DTU-315 for USB-3, and the DTA-2115B for PCIe, which can modulate up to eight 8-MHz channels simultaneously.

An extraordinary achievement in applying software technology was completed by Fabrice Bellard, who started working for DekTec in 2006. He developed software-defined modulators and receivers for nearly all digital-TV modulation standards, running on standard x86 processors. This has enabled DekTec to become the leading supplier of test modulators and receivers, and be actively involved in the development of standards like DVB-T2 and ATSC 3.0.

In recent years, the development focus has shifted to products for developers (OEM). An extensive range of PCIe cards for ASI and SDI interfacing has been created, together with the state-of-the-art DekTec Matrix API® for real-time audio/video processing on PC hardware.

Several video-over-IP cards are in development and will be introduced in 2022 and 2023.

In the 21 years of its existence, DekTec has proven to be an independent and stable company with a complete and consistent product portfolio. An increasing number of

customers rely on DekTec digital-television products for test & measurement, and in 24/7 operational environments.

Organisation

All hardware products are manufactured in the Netherlands. DekTec has built up a sizeable engineering and distribution force, with its head office in Hilversum, two wholly owned sales offices in USA and UK, and development centers in Hilversum, Eindhoven and Denver. More than 40 appointed distributors cover all regions in the world.

DekTec is a member of DVB and ATSC and a registered member of HDMI, IABM, PCI-SIG, SMPTE, USB Forum and VSF.

What's New in 2022

- **DTA-2110**

Full 10GbE NIC optimized for SMPTE 2110.

- **DTA-2116**

An enhanced version of the DTA-2115B; Low profile with improved RF specs and synchronization accuracy.

- **DTA-2127**

Quad satellite receiver for DVB-S/S2/S2X with 3G-SDI/ASI output.

- **DTM-3237B**

Successor of the DTM-3237 OEM satellite receiver with ASI output, now also includes DVB-S2X support.

- **DTU-331**

Portable 0-3GHz RF probe for analyzing any cable, terrestrial or satellite DTV standard.

Strive not to be a success,
but rather to be of value.

Albert Einstein

DTA-2107

Multi-Standard L-Band Modulator

PCI Express

Features

- Satellite modulator with integrated agile L-band upconverter
- DVB-S and DVB-S2 modulation with support for all constellations (incl. 16APSK and 32-APSK) and all roll-off factors (0.20, 0.25, 0.35)
- ISDB-S modulation option with command-line multiplexer to create a valid ISDB-S stream with TMCC data from a standard Transport Stream
- Programmable output level
- AWGN inserter option
- Free Windows and Linux SDK (DTAPI) is fully compatible with other DekTec digital-video output adapters
- PCI Express x1, low profile
- Low profile and standard profile PCI brackets available

Applications

- With *StreamXpress*[®]: Multi-purpose satellite-TV RF signal-generator for R&D, demos, exhibitions, repair
- With MuxXpert: Real-time generation of a DVB-S(2) / ISDB-S signal for single Transport Streams
- With DTAPI: Create your own OEM application that generates a satellite-TV RF signal



Complete DVB-S(2), ISDB-S modulator
Fully agile from 950 to 2150 MHz
AWGN insertion

Key Attributes

Parameter	Value
Modulation	DVB-S(2), ISDB-S, DAB+, I/Q
DVB-S2 constellations	QPSK, 8PSK, 16/32APSK
Roll-off factor	0.20, 0.25, 0.35
Channel filter	256 taps
Symbol rate	0.088 to 45MBd
Symbol rate resolution	<30mBd
Output connector	75-Ω F female
Return loss	>14dB (950 to 2150MHz)
RF output frequency	950 to 2150MHz
RF output level (DVB-S2)	-46.5 to -15.0dBm
RF output level (DVB-S)	-41.5 to -10.0dBm
Phase noise	<-95dBc @ 10kHz
Spurious	>50dB (950 to 2150MHz)
PCI Express	PCIe1 x1 low profile
OS	Windows 10, 11 Windows Server 16, 19, 22 Linux ≥2.6.18, 3.x, 4.x, 5.x

Modulation Standards

Modulation	Standard
DAB+*	EN 300 401
DVB-S	EN 300 421
DVB-S2	EN 302 307
I/Q*	Arbitrary I/Q samples
ISDB-S*	ARIB STD-B20

* Option

Ordering Information

Type	Description
DTA-2107-SP *	L-band modulator with <i>StreamXpress</i> [®]
DTC-305-CM	AWGN inserter option
DTC-371-IQ	IQ sample ployout option
DTC-373-IS	ISDB-S modulation option
DTC-376-DAB	DAB modulation option

DTA-2110

10GbE SFP+ NIC, Optimized for SMPTE 2110

PCI Express

Features

- Standard 10GbE network card with hardware support for the transmission and reception of video, audio and ancillary data according to SMPTE 2110
- Low overhead software interface lets applications interface efficiently with SMPTE 2110 streams
- Insertion of any 10GBASE SFP+ module enables a wide range of 10GbE connection options
- 1GbE electrical or optical is also supported via a 1000BASE-xx SFP+ module
- Local time-of-day counter syncs with PTP network clock and is used for highly accurate packet timestamping and IP traffic shaping
- Encapsulation and decapsulation of SMPTE 2022 TS over-IP streams with FEC support
- TCP/IP task offloading
- Standard Windows and Linux network driver

Applications

- Great platform for creating software-based solutions and products that require SMPTE 2110 input and/or output
- Software encoder with uncompressed audio/video input via SMPTE 2110
- Software decoder with uncompressed audio/video output via SMPTE 2110
- Analysis and monitoring of SMPTE 2110 and SMPTE 2022 streams
- PTP analysis and monitoring
- Playout of SMPTE 2022/2110 streams

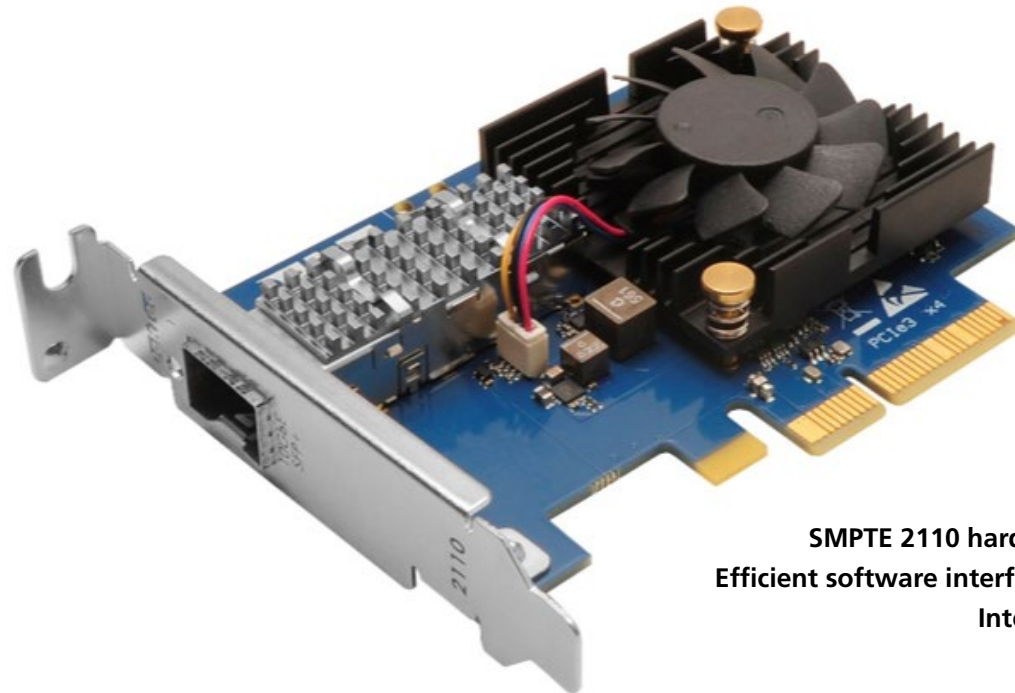

SMPTE 2110 hardware acceleration
Efficient software interface through DTAPI
Integrated in FFmpeg

Key Attributes

Parameter	Value
Physical layer	IEEE 802.3ab/ae 1G/10G autodetect
SFP+ slot	SFF-8431
IP protocol version	IPv4, IPv6
VLAN	IEEE 802.1Q
Video over IP	SMPTE 2110-20/21
Audio over IP	SMPTE 2110-30/31
IP FEC	SMPTE 2022-1
TS over IP	SMPTE 2022-2
SDI over IP	SMPTE 2022-5/6/8
PCI Express	PCIe3 x4 low profile
OS	Windows 10, 11 Windows Server 16, 19, 22 Linux ≥2.6.18, 3.x, 4.x, 5.x

Ordering Information

Type	Description
DTA-2110	10GbE SFP+ NIC for PCIe
DTA-2110-SX	DTA-2110 with <i>StreamXpert</i> [®]
DTA-2110-SY	DTA-2110 with SdEye

DTA-2111

Multi-Standard VHF/UHF Modulator

PCI Express

Features

- Multi-standard modulator for PCI Express with support for most QAM-, OFDM- and VSB-based modulation standards
- Digital upconversion for excellent signal quality without need for calibration
- Supports all constellations and modulation modes for each supported standard
- All-channel upconverter 36 to 1002MHz fully agile over VHF and UHF band
- Digital channel simulator option
- RF output for direct connection to the antenna input of a digital receiver
- Free Windows and Linux SDK (DTAPI) is fully compatible with other DekTec digital-video output adapters
- PCI Express x1, low profile

Applications

- General purpose test modulator
- SMATV, hotel server, shows and exhibitions
- OEM applications



All-digital multi-standard modulator
Fully agile from 36 to 1002MHz
Upgradable to support new standards

Key Attributes

Parameter	Value	
RF connector	75-Ω F female	
Frequency range	36 to 1002MHz ±3ppm	
Bandwidth (max)	8MHz, 16MHz (option)	
I/Q sample rate	4.7 to 9.375MHz	
Level	Range	-32 to -9dBm (QAM) -35 to -12dBm (OFDM)
	Step size	0.1dB
	Accuracy	±2dB
MER	>40dB	
Adjacent channel		-54dB (QAM)
		-52dB (OFDM)
Phase noise	<-95dBc @ 100kHz	
Spectral purity	>50dB @ -9dBm	
Wideband noise	35dBμV (B=1MHz)	
PCI Express	PCIe1 x1 low profile	
OS	Windows 10, 11 Windows Server 16, 19, 22 Linux ≥2.6.18, 3.x, 4.x, 5.x	

Modulation Standards

Standards
ADTB-T*, ATSC, ATSC-M/H*, CMMB*, DAB+*, DMB-T/H*, DVB-C, DVB-C2*, DVB-T, DVB-T2*, I/Q samples*, ISDB-T*, ISDB-Tmm*, QAM-B, QAM-C, T-DMB*

* Option

Ordering Information

Type	Description
DTA-2111-SP	VHF/UHF modulator with <i>StreamXpress</i> ®
DTA-2111-GOLD	DTA-2111 with all options
DTC-371-IQ	I/Q sample payout option
DTC-380-16MHZ	16-MHz bandwidth option
DTC-381-T2SPLP	DVB-T2 single PLP option
DTC-382-Tmm	ISDB-Tmm option
DTC-384-SWMC	Multi-channel software modulation option

DTA-2115B

All-Standard, All-Band Modulator

PCI Express

Features

- High-end test modulator for PCIe with support for all popular digital-TV modulation standards
- All-digital modulation
- Wideband upconverter 32 to 2186MHz, fully agile over VHF, UHF and L-band
- Digital channel simulator option including multipath echo and phase noise simulation
- Ultra low phase noise
- 10-MHz/1pps input for SFN operation or board-to-board synchronization
- Free Windows and Linux SDK (DTAPI) is compatible with DekTec's other modulators and digital-video output adapters

Eight-Channel Firmware

- With the DTC-385-HW8CH option, the DTA-2115B operates as eight independent 8-MHz modulators
- Each modulator is fully agile over the VHF and UHF band (no dependencies between modulators)
- Any combination of terrestrial and cable modulation standards is supported

Applications

- The ultimate test modulator in the lab
- Generation of a network of channels in a test and validation environment using *StreamXpress*[®]
- Play back of I/Q samples up to 72MHz bandwidth



Fully agile from 32 to 2186MHz
Single 72-MHz or eight 8-MHz channels
Supports new DVB-S2 extensions (DVB-S2X)

Key Attributes

Parameter	Value	
Main output	RF connector	50-Ω SMA female
	RF level	-60 to 0dBm
	Step size	0.1dB
Monitor output	RF connector	75-Ω F female
	RF level	-45dBm
10-MHz/1pps input	2x 50-Ω BNC female	
Frequency range	32 to 2186MHz	
Symbol rate	88kbaud to 85Mbaud	
I/Q sample rate	88kHz to 85MHz	
Bandwidth (max)	72MHz	
Transmit MER (typical)	42dB	
Phase noise	<-110dBc @ 10kHz	
Spectral flatness over 8MHz	0.5dB	
Spectral purity	>50dB	
PCI Express label	PCIe3 x1	
OS	Windows 10, 11 Windows Server 16, 19, 22 Linux ≥2.6.18, 3.x, 4.x, 5.x	

* If the DTA-2115B is used in a PCIe gen 2 slot, certain sample rate restrictions will apply.

Modulation Standards

Standards
ADTB-T*, ATSC, ATSC-M/H*, ATSC 3.0*, CMMB*, DAB+*, DMB-T/H*, DVB-C, DVB-C2*, DVB-CID, DVB-S, DVB-S2, DVB-S2X*, DVB-T, DVB-T2 single PLP, DVB-T2 (full)*, I/Q samples*, ISDB-S*, ISDB-S3*, ISDB-T*, ISDB-Tmm*, QAM-B, QAM-C, T-DMB*

* Option

Ordering Information

Type	Description
DTA-2115B-SP	All standard, all-band modulator for PCIe with <i>StreamXpress</i> [®]
DTA-2115B-GOLD	DTA-2115B-SP with all current and future modulation options
DTC-371-IQ	I/Q sample playback option
DTC-380-16MHZ	16-MHz bandwidth option
DTC-381-T2SPLP	DVB-T2 single PLP option
DTC-382-Tmm	ISDB-Tmm option
DTC-385-HW8CH	8-channel modulation firmware option

DTA-2116

All-Standard 0-3GHz Modulator

PCI Express

Features

- High-end test modulator for cable, terrestrial and satellite DTV modulation standards
- Playout of I/Q samples anywhere in the 0-3GHz range, to generate arbitrary RF signals
- Programmable RF level calibrated in the factory
- 10MHz/1PPS input for accurate synchronization to a (GPS) timing reference source
- 1PPS input can be used to trigger I/Q playout on multiple DTA-2116s with sub-ns sync precision
- SDR architecture with digital modulation and upconversion for future proofing and achieving the highest possible signal quality
- Digital channel simulator option including multipath echo and addition of AWGN noise
- Free Windows and Linux SDK (DTAPI) is compatible with DekTec's other modulators and digital-video output adapters

Applications

- General-purpose test modulator in your R&D lab for developing and qualifying DTV equipment, or for experimentation with new RF modulation schemes
- Playback of I/Q samples up to 100MHz bandwidth
- GPS simulator
- Automatic test equipment (ATE) for tuners, demodulator chips, receivers, TV sets etc.
- SFN testing and simulation



Fully agile from 32 to 3225MHz
The ultimate test modulator in your lab
Accurate GPS and board-to-board synchronization

Key Attributes

Parameter		Value
Main output	RF connector	50-Ω SMA female
	RF level	-80 to 0dBm
	Step size	0.1dB
Monitor output	RF connector	75-Ω F female
	RF level	-45dBm
10-MHz/1pps input		2x 50-Ω SMA female
Frequency range		32 to 3225MHz
I/Q sample rate		0.1 to 125Msps
Bandwidth (max)		100MHz
Sync accuracy		±0.5ns @ 25°C
Transmit MER (typical)		≥50dB
Phase noise		-116dBc @ 10kHz
Spectral purity		≥50dB
PCI Express		PCIe3 x4 low profile
OS		Windows 10, 11
		Windows Server 16, 19, 22
		Linux ≥2.6.18, 3.x, 4.x, 5.x

Modulation Standards

Standards
ADTB-T*, ATSC, ATSC-M/H*, ATSC 3.0*, CMMB*, DAB+*, DMB-T/H*, DVB-C, DVB-C2*, DVB-CID, DVB-S, DVB-S2, DVB-S2X*, DVB-T, DVB-T2 single PLP, DVB-T2 (full)*, I/Q samples*, ISDB-S*, ISDB-S3*, ISDB-T*, ISDB-Tmm*, QAM-B, QAM-C, T-DMB*

* Option

Ordering Information

Type	Description
DTA-2116-SP	All-standard 0-3GHz modulator for PCIe with StreamXpress®
DTA-2116-GOLD	DTA-2116-SP with all current and future modulation options
DTC-371-IQ	I/Q sample playout option
Other options	Refer to the DekTec website

DTA-2127

Quad DVB-S2X Receiver with 3G-SDI/ASI Output

PCI Express

Features

- Quad satellite receiver with DVB-S2X support and 3G SDI/ASI output port
- LNB power insertion (13V/18V 400mA) with DiSEqC interface on each port
- Receiver provides lock status, RF level, demodulation status, modulation type, code rate, SNR, MER and BER
- SDI/ASI output port configuration*:
 - o ASI or SDI
 - o SDI: 3G, HD or SD
 - o 3G-SDI: level A or level B
- Free Windows and Linux SDK (DTAPI) is fully compatible with other DekTec digital video adapters
- PCI Express gen1 x4

* 3G-SDI/ASI input configuration available on request

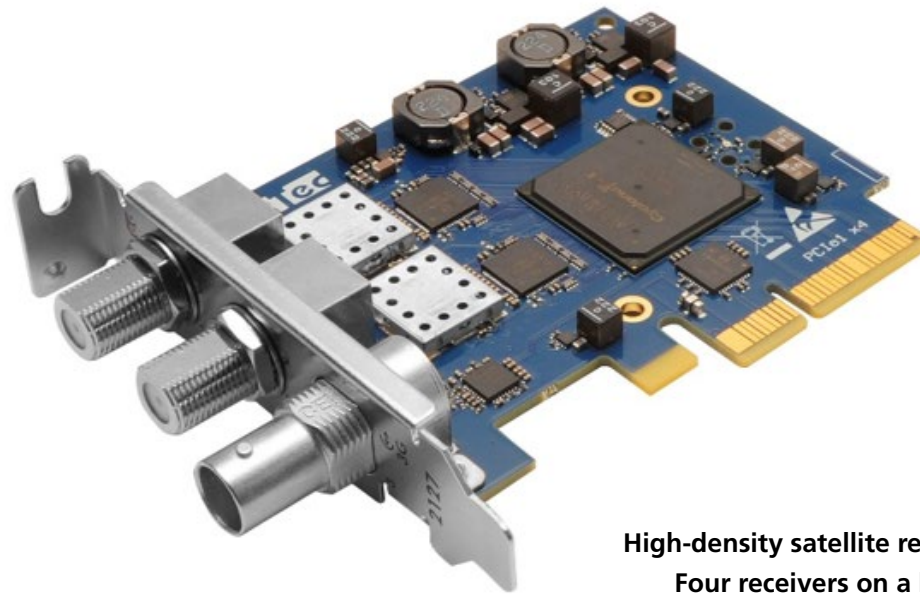

High-density satellite receiver with DVB-S2X
Four receivers on a low-profile PCIe card
Use SDI/ASI output for creating an IRD

Applications

- Satellite gateway for TV or data distribution
- Satellite monitoring
- Local redistribution of DVB-S2/S2X channels with DekTec's remultiplexer MuxXpert

Key Attributes

Parameter	Value	
Antenna inputs	2x 75-Ω "F" Female	
Number of receivers	4	
Tuning range	950 to 2150MHz	
Input sensitivity	-60 to -30dBm	
Symbol rate	1 to 45MSps	
Return Loss	>10dB @ 0 to 2GHz	
Metrology	BER	Pre/Post
	Constellation	2D
PCI Express	PCIe1 x4 low profile	
OS	Windows 10, 11 Windows Server 16, 19, 22 Linux ≥2.6.18, 3.x, 4.x, 5.x	

Modulation Standards

Modulation	Standard
DVB-S	EN 300 421
DVB-S2	EN 302 307
DVB-S2X	EN 302 307-2

Ordering Information

Type	Description
DTA-2127	Quad DVB-S2X receiver with 3G-SDI/ASI output
DTA-2127-SX	DTA-2127 with <i>StreamXpert</i> ®

DTA-2131

Multi-Standard VHF/UHF Receiver

PCI Express

Features

- Tuner, I/Q demodulator and sample-rate converter, optimized for use with SDR technology (Software Defined Radio = demodulation in software)
- Several software demodulators available, including ATSC 3.0, DVB-C2 and DVB-T2, with features and measurements exceeding those of consumer demodulator chips
- Hardware sample rate converter for obtaining I/Q samples at a convenient rate
- MER measurements in OFDM up to an accuracy of 42dB
- Multiple demodulated streams and advanced measurements available through Advanced Demodulator API (available for Windows and Linux, part of DTAPI)
- PCI Express x1, low profile
- Low profile and standard profile PCI brackets available

Applications

- RF network monitoring with measurements
- Universal receiver
- Front end for SDR experiments

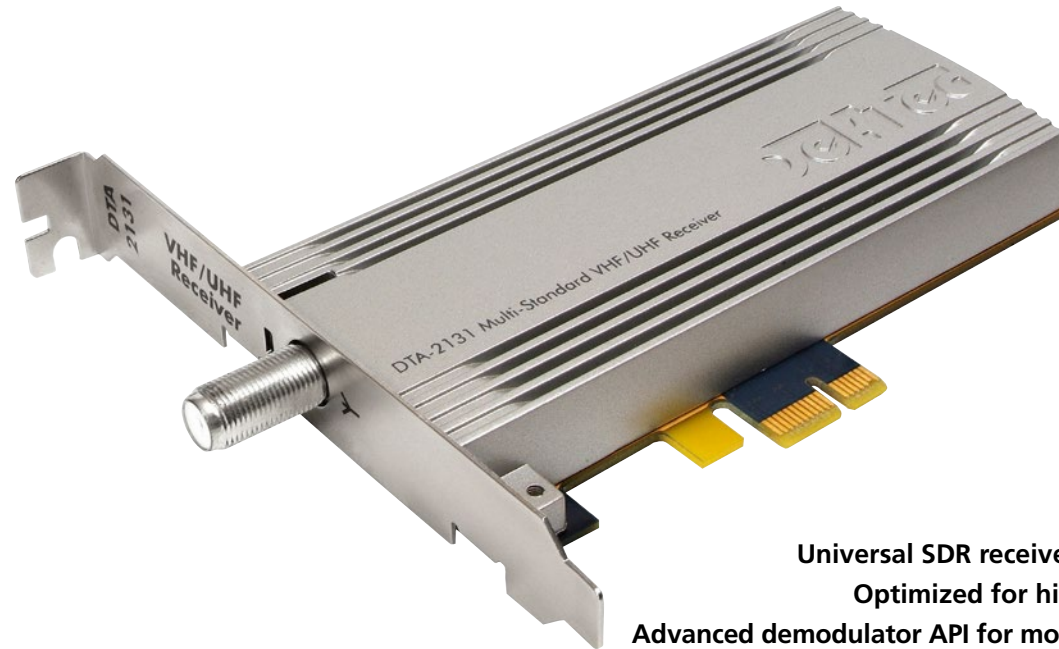

Universal SDR receiver for VHF/UHF band
Optimized for high-quality reception
Advanced demodulator API for monitoring applications

Key Attributes

Parameter	Value	
RF input	75-Ω F female	
Input return loss	>8dB	
Tuning range	42 to 870MHz	
Bandwidth	1.7, 6, 10, 11MHz	
Input sensitivity	-90 to -20dBm	
I/Q sample rate	1.25 to 40Msps	
I/Q sample size	16-bit I + 16-bit Q	
SNR	50dB	
Metrology	MER	10 to 42dB
	RF level	-90 to -20dBm
	RF level accuracy	±3dB
Power consumption	4.7W typ	
Environmental temperature	0 to 45°C	
PCI Express	PCIe1 x1 low profile	
OS	Windows 10, 11 Windows Server 16, 19, 22 Linux ≥2.6.18, 3.x, 4.x, 5.x	

Received Standards

Type	Description
ATSC 8VSB	ATSC A/53E
ATSC 3.0	ATSC Doc. A/322
DAB+	EN 300 401
DVB-C	EN 300 429
DVB-C2	EN 302 769
DVB-T	EN 300 744
DVB-T2	EN 302 755
ISDB-T	ARIB STD-831
QAM	J.83 Annex A/B/C

Ordering Information

Type	Description
DTA-2131-XPRT	Multi-standard VHF/UHF receiver with <i>Atsc3Xpert</i> , <i>C2Xpert</i> and <i>T2Xpert</i>
DTA-2131-XPRT-SX	Multi-standard VHF/UHF receiver with <i>Atsc3Xpert</i> , <i>C2Xpert</i> , <i>T2Xpert</i> and <i>StreamXpert</i> ®

DTA-2132

High-End Satellite Receiver

PCI Express

Features

- Professional grade satellite receiver with high-quality metrics
- FPGA-based DVB-S2/S2X demodulation
- Direct I/Q samples for recording or SDR
- Reception of BBFRAMEs in L.3 packets
- Supports advanced DVB-S2 features: VCM, ACM, Multiple Input Streams (MIS) and Generic Stream (GS)
- LNB power insertion and DiSEqC support
- Free Windows and Linux SDK (DTAPI) is compatible with other DekTec adapters
- PCI Express gen2 x4, low profile

Applications

- General purpose satellite receiver with full transport stream output
- High-speed data distribution
- DVB-S2 and S2X monitoring solutions
- DAB, DSNG, DTT, OTT contribution

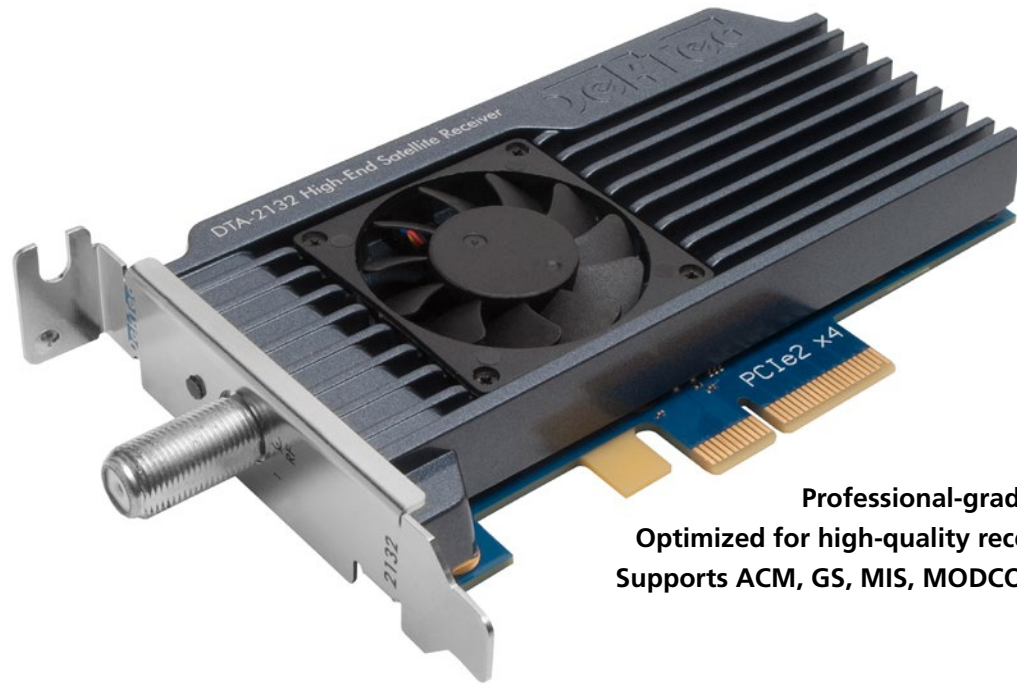

Professional-grade satellite receiver
Optimized for high-quality reception and metrics
Supports ACM, GS, MIS, MODCODs up to 256APSK

Key Attributes

Parameter	Value	
Antenna input	75-Ω "F" Female	
Input return loss	> 12dB	
Tuning range	950 to 2150MHz	
Input sensitivity	-80 to -20dBm *	
Baud rate	0.05 to 72MBaud	
Metrology	RF level	-80 to -20dBm ±1.5dB
	MER	3 to 35dB
	Constellation	256 x 256
PCI Express	PCIe2 x4 low profile	
OS	Windows 10, 11 Windows Server 16, 19, 22 Linux ≥2.6.18, 3.x, 4.x, 5.x	

* When using 256-APSK: -60 to -20dBm

Modulation Standards

Modulation	Standard
DVB-S	EN 300 421
DVB-S2	EN 302 307
DVB-S2X	EN 302 307-2
ISDB-S	ARIB STD-B20 *
ISDB-S3	ARIB STD-B44 *

* Please check DekTec website for availability

Ordering Information

Type	Description
DTA-2132	High-end satellite receiver for PCIe
DTA-2132-SX	DTA-2132 with <i>StreamXpert</i> [®]

DTA-2138B

DVB-T2/C2/ISDB-T Receiver

PCI Express

Features

- Single-channel DVB-T2, DVB-C2 and ISDB-T receiver for VHF/UHF with support for DVB-T2 Lite
- Full support for legacy DVB-C and DVB-T
- Hardware-based demodulation with 0% CPU load
- Support for all DVB-T2 modes, including single and multiple PLP, SISO and MISO
- Professional RF measurements including RF level, MER and constellation diagram
- Free Windows and Linux SDK (DTAPI) is fully compatible with other DekTec digital-television adapters
- PCI Express x1, low profile
- Low profile and standard profile PCI brackets available

Applications

- Monitoring of DVB-T/T2, DVB-C/C2 or ISDB-T networks
- DVB-T/T2, DVB-C/C2, ISDB-T test receiver
- Re-multiplexing of DVB-C/T/C2/T2 or ISDB-T with DekTec's *MuxXpert* software

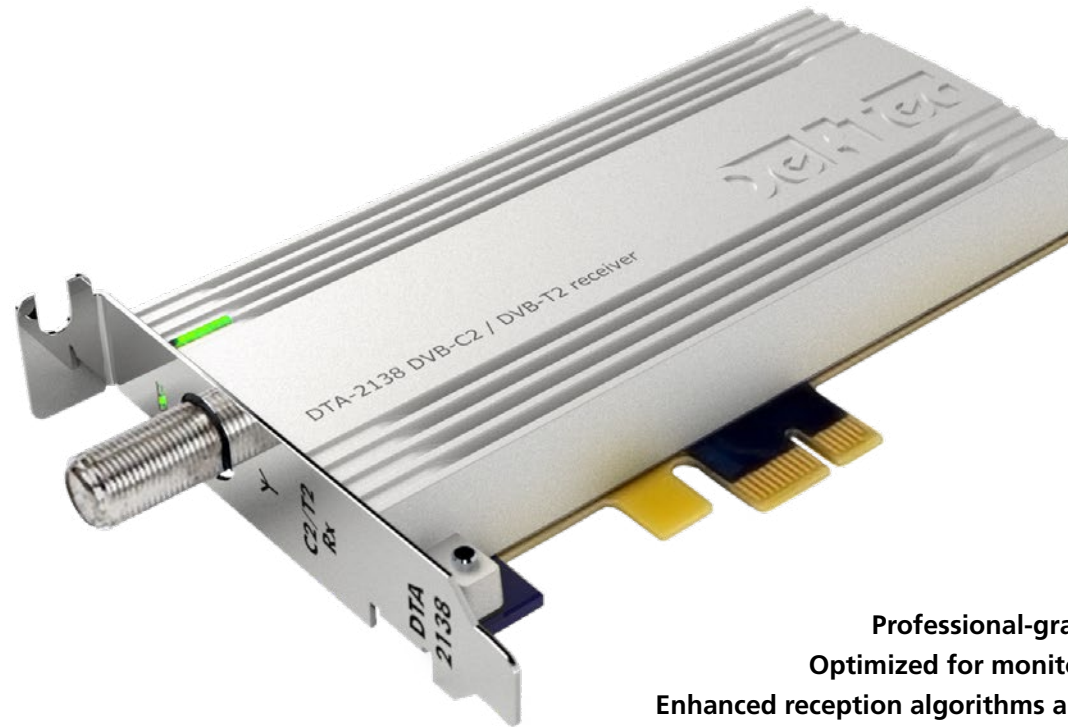

Professional-grade T2/C2 receiver
Optimized for monitoring applications
Enhanced reception algorithms and measurements

Key Attributes

Parameter	Value
RF input	75-Ω "F" female
Input return loss	>8dB
Tuning range	42 to 880MHz
Bandwidth	1.7/5/6/7/8 MHz
Input sensitivity	-80 to -15dBm
DVB-C	EN 300 429
DVB-C2	EN 302 769
DVB-T	EN 300 744
DVB-T2	EN 302 755 v1.3.1 (DVB-T2 Lite)
ISDB-T	ARIB STD-B31
PCI Express	PCIe1 x1 low profile
OS	Windows 10, 11 Windows Server 16, 19, 22 Linux ≥2.6.18, 3.x, 4.x, 5.x

Related Products

Modulation	Standard
DTA-2131	Multi-standard VHF/UHF receiver
DTA-2127	Hardware-based DVB-S2X receiver
DTA-2139C	Twelve-channel cable/terrestrial receiver

Ordering Information

Type	Description
DTA-2138B-SL	DVB-C2 / DVB-T2 receiver with <i>StreamXpert® Lite</i>
DTA-2138B-SX	DTA-2138B-SL with <i>StreamXpert®</i>

DTA-2139C

Twelve-channel Cable/Terrestrial Receiver

PCI Express

Features

- Twelve independent receivers for any mix of ATSC VSB, ATSC 3.0, DVB-C, DVB-C2, ITU J.83, DVB-T, DVB-T2 and ISDB-T signals
- Applications have access to the complete Transport Stream for each receiver
- Each channel provides reception status, RF level, demodulation status, constellation, SNR and post-FEC BER
- PCI Express gen1 x4
- Free Windows and Linux SDK (DTAPI) is fully compatible with other DekTec digital video adapters

Applications

- Reception and processing of multiple channels in any combination, e.g. ATSC VSB and ATSC 3.0
- Monitoring of cable and terrestrial networks
- Testing and validation of edge-QAM systems



Twelve independent cable/terrestrial receivers
Full TS available from each receiver
Includes ATSC 3.0, DVB-T2 and ISDB-T support

Key Attributes

Parameter	Value	
Input connector	75-Ω F Female	
Number of receivers	12	
Return loss	>10dB	
Tuning range	42 .. 1002MHz	
Input sensitivity	-80 .. -20dBm typical*	
Symbol rate	1.7 .. 7.2MBaud	
Metrology	RF level	-80 .. -20dBm ±3dB
	MER	3 .. 40dB
	BER	Post decoder
	Constellation	2D
PCI Express	PCIe1 x4	
OS	Windows 10, 11 Windows Server 16, 19, 22 Linux ≥2.6.18, 3.x, 4.x, 5.x	

* Using least robust mode: -75 to -20dBm for DVB-T; -65 to -20dBm for DVB-C

Modulation Standards

Modulation	Standard
ATSC VSB	ATSC A53/E
ATSC 3.0	ATSC A/322
DVB-C	EN 300 429
DVB-C2	EN 302 769
DVB-T	EN 300 744
DVB-T2	EN 302 755 v1.3.1 (DVB-T2 Lite) DTG6.2/7, NorDig-U v2.2
ISDB-T	ARIB STD-B31
QAM-B	ITU J.83 Annex B
QAM-C	ITU J.83 Annex C

Ordering Information

Type	Description
DTA-2139C-SL	DTA-2139C with <i>StreamXpert® Lite</i>
DTA-2139C-SX	DTA-2139C with <i>StreamXpert®</i>

DTA-2144B

Quad ASI/SDI Adapter

PCI Express

Features

- Four ASI/SDI ports with individual status LEDs
- Each port can be independently configured as input, output or copy of another channel
- Cable equalisation and inverted ASI
- Support for genlock
- Hardware counters for bitrate measurement and statistics
- Flexible receive modes with time-stamping, packet sequence counting and false-sync pass through for full TR 101 290 support
- 10-bit SDI, full stream @ 270Mbit/s
- Lossless SDI Huffman encoding / decoding for reduction of bus bandwidth
- PCI Express x4

Applications

- Transport-stream multiplexing
- Monitoring of multiple MPEG-2 transport streams and/or SDI serial digital video streams
- Universal ASI/SDI input/output adapter for PC-based applications that record, play and/or process ASI or SDI

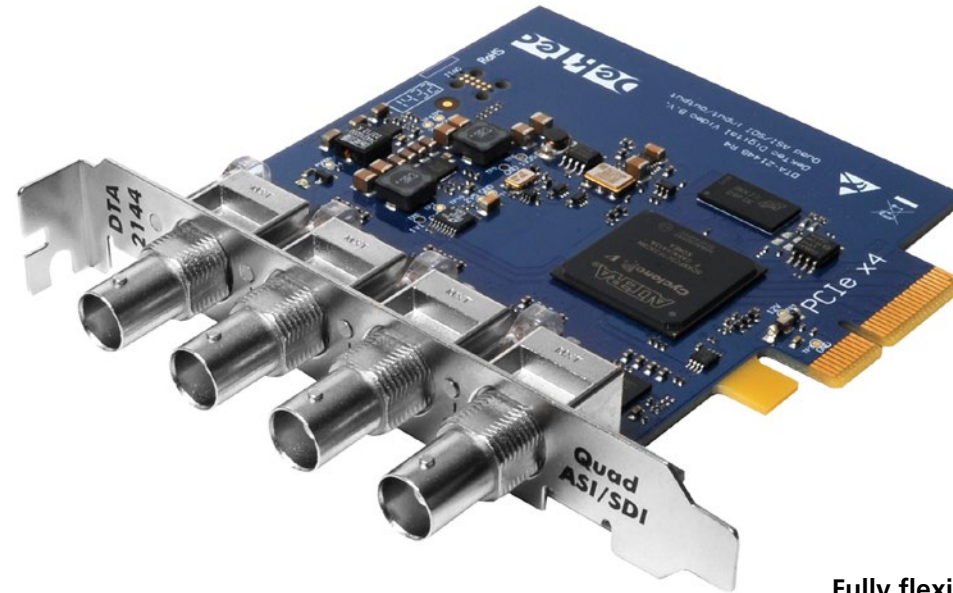

Fully flexible port configuration
PCI Express x4 for ample bandwidth
Supports DVB-ASI and full-frame SDI

Key Attributes

Parameter	Value	
ASI/SDI connector	75-Ω BNC (4x)	
Input return loss	>15dB	
Hardware buffering	32MB/channel	
ASI	Physical layer	DVB-ASI (coax) EN50083-9
	Rx or Tx bitrate	0 to 214Mbit/s
	Resolution	<1bit/s
SDI	Physical layer	SMPTE 259M/C
	Bitrate	270Mbit/s
	#Bits	8 or 10bit
PCI Express	PCIe1 x4	
OS	Windows 10, 11 Windows Server 16, 19, 22 Linux ≥2.6.18, 3.x, 4.x, 5.x	

Related PCI-Express Products

Type	Description
DTA-2175	ASI/SDI input+output with fail-over
DTA-2178-ASI	Octal ASI ports

Ordering Information

Type	Description
DTA-2144B-SLP	Quad ASI/SDI I/O adapter for PCI Express with <i>StreamXpress</i> ® and <i>StreamXpert</i> ® Lite
DTA-2144B-SXP	DTA-2144B-SLP with <i>StreamXpert</i> ®
DTA-2144B-SY-SLP	DTA-2144B-SLP with <i>SdEye</i>
DTA-2144B-SY-SXP	DTA-2144B-SLP with <i>SdEye</i> and <i>StreamXpert</i> ®

DTA-2145

Dual ASI/SDI Adapter

Features

- Two BNC ports: one dedicated ASI/SDI output port and one software-selectable ASI/SDI input- or second independent output port, with status LED
- All hardware and software features found in the market place, plus more
- Watchdog-controlled input-to-output relay for redundant configurations
- Support for genlock
- Cable equalisation and inverted ASI
- Bitrate measurement and statistics
- Flexible receive modes with time-stamping, packet-sequence counting and false-sync pass through for full TR 101 290 support
- Lossless SDI Huffman encoding / decoding
- PCI Express x1, low profile
- Low profile and standard profile PCI brackets available

Applications

- ASI/SDI stream station
- High-availability ASI/SDI generation
- ASI/SDI analysis or monitoring
- Universal ASI/SDI input/output adapter for PC-based applications that record, play and/or process MPEG-2 transport streams and/or SDI digital video

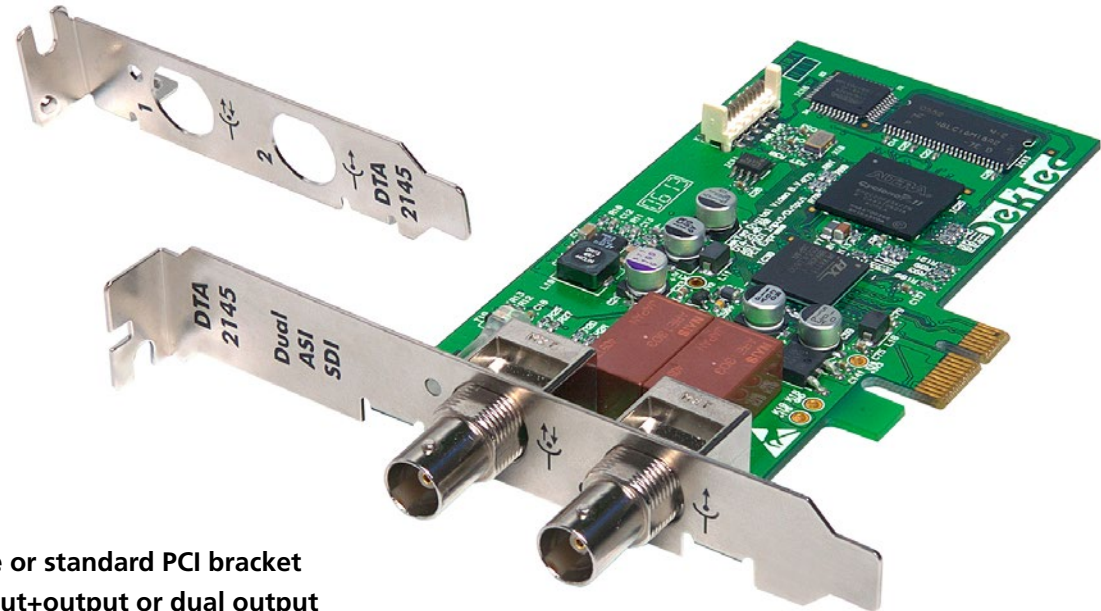

Low profile or standard PCI bracket
ASI/SDI input+output or dual output
Most complete feature set in the market

Key Attributes

Parameter	Value	
Connector	75-Ω BNC (2x*)	
Return loss	> 15dB	
Hardware buffering	16MB/channel	
ASI	Physical layer	DVB-ASI (coax) EN50083-9
	Bitrate range	0 to 214Mbit/s
	Packet size	188 or 204**
SDI	Physical layer	SMPTE 259M/C
	Bitrate	270Mbit/s
	#Bits	8 or 10bit
PCI Express	PCIe1 x1 low profile	
OS	Windows 10, 11 Windows Server 16, 19, 22 Linux ≥2.6.18, 3.x, 4.x, 5.x	

* 1xOutput port and 1xsoftware-selectable input or output port

** Arbitrary packet size in raw mode

Related Products

Type	Description
DTA-2175	HD-SDI/ASI input + output with relay bypass

Ordering Information

Type	Description
DTA-2145-SLP	Dual ASI/SDI I/O adapter for PCI Express with <i>StreamXpress</i> ® and <i>StreamXpert</i> ® Lite
DTA-2145-SXP	DTA-2145-SLP with <i>StreamXpert</i> ®
DTA-2145-SY-SLP	DTA-2145-SLP with <i>SdEye</i>
DTA-2145-SY-SXP	DTA-2145-SLP with <i>SdEye</i> and <i>StreamXpert</i> ®

DTA-2160

Triple ASI Ports and GigE Network Port

PCI Express

Features

- General-purpose transmission and reception of Transport Streams over ASI links and IP networks
- IP encapsulation in accordance with SMPTE 2022-1 and 2022-2
- Zero-jitter playout of multiple TS-over-IP streams
- Source-specific multicast (SSM) support
- Generation of two-dimensional FEC with programmable dimensions D and L and block-aligned FEC linearization
- Re-ordering and error correction of TS-over-IP streams with programmable latency
- Time stamping of incoming IP packets to enable TS-over-IP jitter analysis
- Comes with NDIS network driver for Windows and Linux network driver

Applications

- Contribution, primary distribution over IP
- Multipurpose ASI/TS-over-IP stream station
- Jitter measurements of TS-over-IP streams
- General-purpose ASI and TS-over-IP inputs and outputs for OEM applications



Gigabit Ethernet 10/100/1000 port
Three bi-directional DVB-ASI ports
Create your own IP/ASI stream station

Key Attributes

Parameter	Value	
TS-over-IP	Physical layer	IEEE 802.3ab
	Data rate	10/100/1000
	Connector	RJ-45
	Maximum TS rate	600Mbit/s
	Parallel TS-over-IP streams	100+*
ASI	Physical layer	DVB-ASI (coax)
	Connector	75-Ω BNC (3x)
	Rx or Tx bitrate	0 to 214Mbit/s
	Resolution	<1bit/s
Transport packets per IP	1,2,3,4,5,6 or 7	
TS-over-IP protocol	UDP or RTP	
TS-over-IP FEC and Encapsulation	SMPTE 2022	
Transcoding rate	0 to 200Mbit/s	
PCI Express	PCIe1 x4	
OS	Windows 10, 11 Windows Server 16, 19, 22 Linux ≥2.6.18, 3.x, 4.x, 5.x	

* Limited only by cumulative TS rate and PC resources

Related Products

Type	Description
DTA-2162	Dual GigE ports for PCIe
DTE-3100	Low-latency TS-over-IP to ASI converter
DTE-3120	Low-latency ASI to TS-over-IP converter
DTM-3200	OEM TS-over-IP from/to ASI converter

Ordering Information

Type	Description
DTA-2160-SLP	Triple ASI and GigE port for PCIe with <i>StreamXpress®</i> and <i>StreamXpert® Lite</i>
DTA-2160-J-SXP	DTA-2160-SLP with <i>DtJitter</i> and <i>StreamXpert®</i>

The DTA-2160 is still in production but is coming toward the end of its life cycle. Therefore, the DTA 2160 is not recommended for new designs.

DTA-2162

Dual GigE Ports with Hardware Accelerated DTV Streaming

PCI Express

Features

- Two 100/1000 IEEE 802.3ab network ports enhanced with hardware-accelerated DTV streaming functions
- Greatly simplifies generation and consumption of TS-over-IP streams in your custom application
- Facilitates working with redundant TS-over-IP streams for creating highly-available networks
- Encapsulation and decapsulation of TS-over-IP streams with FEC support
- Hardware-based IP address filtering
- On-board packet scheduling engine for zero-jitter playout
- IP packet timestamping for jitter analysis or smoothing
- Supports TCP/IP task offloading to save CPU cycles
- Free Windows and Linux SDK (DTAPI) is fully compatible with other DekTec digital-television adapters
- Standard Windows and Linux network driver so that DTA-2162 ports can be used as standard network interface
- PCI Express x4, low profile
- Low- and standard profile PCI brackets available

Applications

- Monitoring of fully loaded Gigabit Ethernet links
- TS-over-IP processing of hundreds of streams
- Highly-available IP-based encoding, transcoding and multiplexing systems
- TS-over-IP stream station

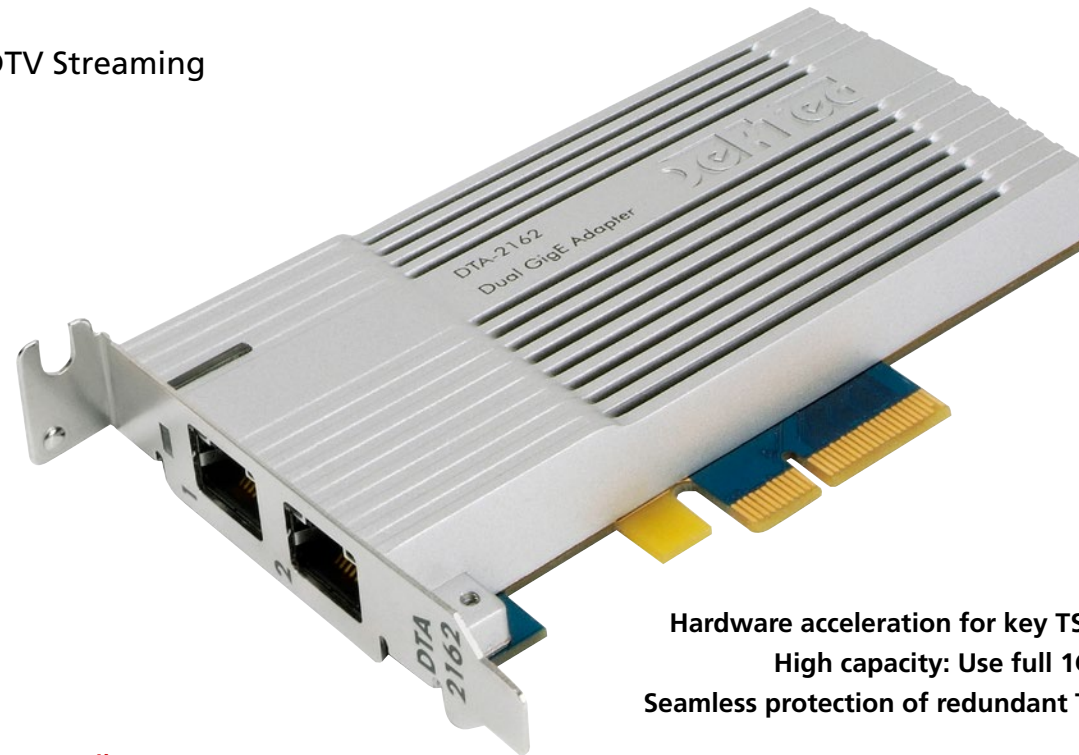

Hardware acceleration for key TS-over-IP functions
High capacity: Use full 1Gbps on each port
Seamless protection of redundant TS-over-IP streams (SMPTE 2022-7)

Key Attributes

Parameter	Value
Physical layer	IEEE 802.3ab
Ports	2x 100/1000 auto
Connector	RJ-45 with LEDs
IP protocol version	IPv4, IPv6
Seamless IP protection	SMPTE 2022-7
VLAN	IEEE 802.1Q
Maximum aggregated rate	1Gbps per port
Parallel TS-over-IP streams	200+*
TS-over-IP protocol	UDP or RTP
IP FEC	SMPTE 2022-1
IP encapsulation	SMPTE 2022-2
PCI Express	PCIe1 x4 low profile
OS	Windows 10, 11 Windows Server 16, 19, 22 Linux ≥2.6.18, 3.x, 4.x, 5.x

* Limited only by cumulative TS rate and PC resources

Related Products

Type	Description
DTA-2110	10GbE SFP+ NIC for PCIe
DTA-2160	Triple ASI and GigE port for PCIe
DTE-3100	Low-latency TS-over-IP to ASI converter
DTE-3120	Low-latency ASI to TS-over-IP converter
DTM-3200	OEM TS-over-IP from/to ASI converter

Ordering Information

Type	Description
DTA-2162-SLP	Dual GigE ports for PCIe with <i>StreamXpress®</i> and <i>StreamXpert® Lite</i>
DTA-2162-J-SXP	DTA-2162-SLP with <i>DtJitter</i> and <i>StreamXpert®</i>

The DTA-2162 is still in production but is coming toward the end of its life cycle. Therefore, the DTA 2162 is not recommended for new designs.

DTA-2172

Dual 3G-SDI/ASI Ports with Genlock

PCI Express

Features

- Each port is fully configurable from software:
 - Input or output
 - ASI or SDI
- Bi- and tri-level genlock input port
- Low latency DMA to and from software
- No need to know the low-level structure of SDI, with DekTec Matrix API® 2.0 you can work directly with audio and video samples, pixel format conversions, ANC data insertion/extraction and video scaling

Applications

- “Inline” processing of SDI or ASI signals, e.g. logo/subtitle inserter, audio embedder, etc.
- Multi-channel transcoding to/from IP
- High-availability SDI/ASI generation
- SDI/ASI analysis or monitoring

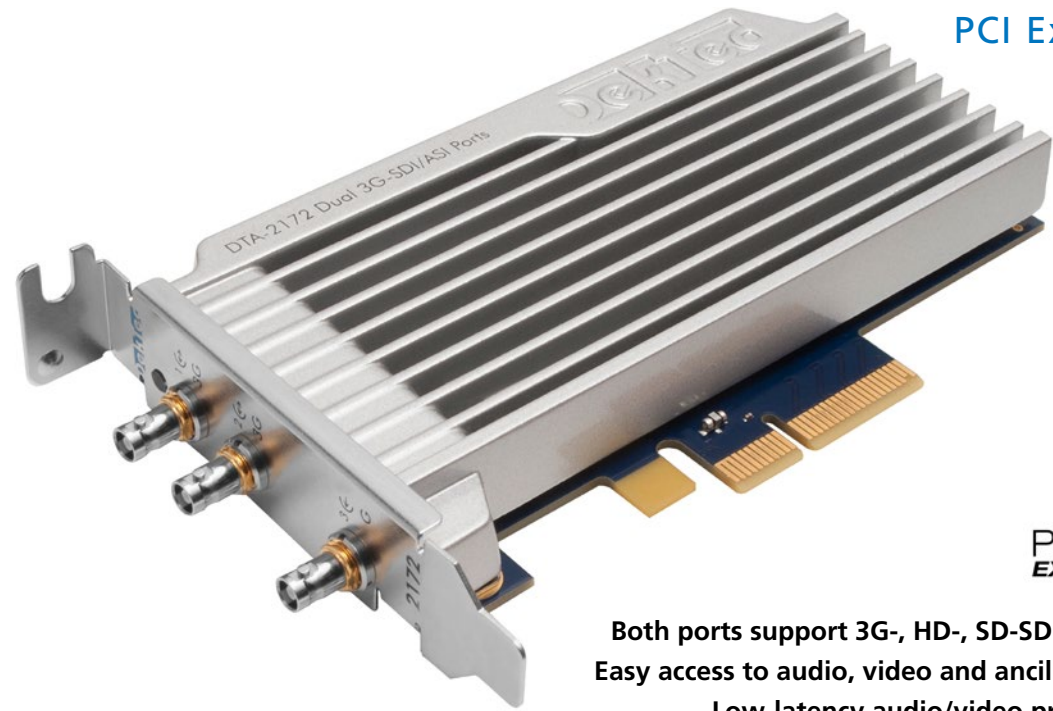

Both ports support 3G-, HD-, SD-SDI and ASI
Easy access to audio, video and ancillary data
Low-latency audio/video processing

Key Attributes

Parameter	Value
Ports	2 SDI/ASI ports, 1 genlock port
Physical layer	DVB-ASI : EN50083-9 SD-SDI : SMPTE 259M HD-SDI : SMPTE 292M 3G-SDI : SMPTE 424M
Connectors	3x 75-Ω micro BNC
Cable length	ASI/SD_SDI 350m HD-SDI 200m 3G-SDI 150m
Matrix API 2.0	8/10/16-bit conversion Audio/video/ANC extraction Scaling by 1/4 or 1/16 Access to all 16 audio channels
PCI Express	PCIe2 x4 low profile
OS	Windows 10, 11 Windows Server 16, 19, 22 Linux ≥2.6.18, 3.x, 4.x, 5.x

Related Products

Type	Description
DTA-2174B	Quad 12G/3G-SDI/ASI with Genlock
DTA-2175	ASI/SDI input+output with fail-over
DTA-2178	Octal 12G-SDI/ASI Ports with Genlock

Ordering Information

Type	Description
DTA-2172	Dual 3G-SDI/ASI ports for PCIe
DTA-2172-SXP	DTA-2172 with <i>StreamXpress</i> ®, <i>StreamXpert</i> ®
DTA-2172-SY-SXP	DTA-2172 with <i>SdEye</i> , <i>StreamXpress</i> ®, <i>StreamXpert</i> ®

DTA-2174B

Quad 3G-SDI/ASI Ports (1x12G) with Genlock

PCI Express

Features

- Each port is fully configurable from software:
 - Input or output
 - ASI or SDI
 - SDI: SD, HD, 3G A+B
 - Port 1 can be configured for 6G and 12G-SDI
- Bi- and tri-level genlock input port
- Low latency DMA to and from software
- No need to know the low-level structure of SDI, with DekTec Matrix API® 2.0 you can work directly with audio and video samples, pixel format conversions, ANC data insertion/extraction and video scaling

Applications

- Software-based 4K decoder and/or encoder with 12G-SDI or quad-link 3G-SDI interfacing
- 4K decoder with 12G-SDI and downscaled triply buffered HD/3G-SDI monitoring output
- Live production mixers
- Multi-channel decoding, encoding, monitoring, multiplexing, stream processing, transcoding
- SDI multiviewer
- Compliance recorder



**All ports support 3G, one port 12G capable
Uncompressed 4K over 12G-SDI or quad-link
Easy access to audio, video and ancillary data**

Key Attributes

Parameter	Value
Ports	4 SDI/ASI ports, 1 genlock port
Physical layer	DVB-ASI : EN50083-9 SD-SDI : SMPTE 259M HD-SDI : SMPTE 292M 3G-SDI : SMPTE 424M 6G-SDI : SMPTE 2081 12G-SDI : SMPTE 2082
Connectors	5x 75-Ω micro BNC
Cable length	ASI/SD-SDI 350m HD-SDI 200m 6G SDI 55m 3G-SDI 150m 12G SDI 50m
Matrix API 2.0	8/10/16-bit conversion Audio/video/ANC extraction Scaling by 1/4 or 1/16 Access to all 16 audio channels
PCI Express	PCIe3 x4 low profile
OS	Windows 10, 11 Windows Server 16, 19, 22 Linux ≥2.6.18, 3.x, 4.x, 5.x

Related Products

Type	Description
DTA-2172	Dual 3G-SDI/ASI Ports with Genlock
DTA-2178	Octal 12G-SDI/ASI Ports with Genlock
DTA-2179	Twelve 3G-SDI/ASI Ports with Genlock

Ordering Information

Type	Description
DTA-2174B	Quad 3G-SDI/ASI ports for PCIe
DTA-2174B-SXP	DTA-2174B with <i>StreamXpress</i> ®, <i>StreamXpert</i> ®
DTA-2174B-SY-SXP	DTA-2174B with <i>SdEye</i> , <i>StreamXpress</i> ®, <i>StreamXpert</i> ®

DTA-2175

HD-SDI/ASI Input + Output with Relay Bypass

PCI Express

Features

- One dedicated SDI/ASI input and one dedicated SDI/ASI output, both supporting up to HD-SDI
- Watchdog-controlled input-to-output relay bypass for failsafe configurations
- DekTec Matrix API® 2.0 takes care of all the plumbing for creating robust real-time SDI processing applications
- Cable equalization and inverted ASI
- Bitrate measurement and statistics
- Flexible receive modes with time-stamping, packet-sequence counting and false-sync pass through for full TR 101 290 support
- PCI Express gen2 x1, low profile

Applications

- “Inline” processing of SDI or ASI signals, e.g. logo/subtitle inserter, audio embedder, etc.
- ASI-to-SDI software decoder
- SDI-to-ASI software encoder
- High-availability SDI/ASI generation
- SDI/ASI analysis or monitoring

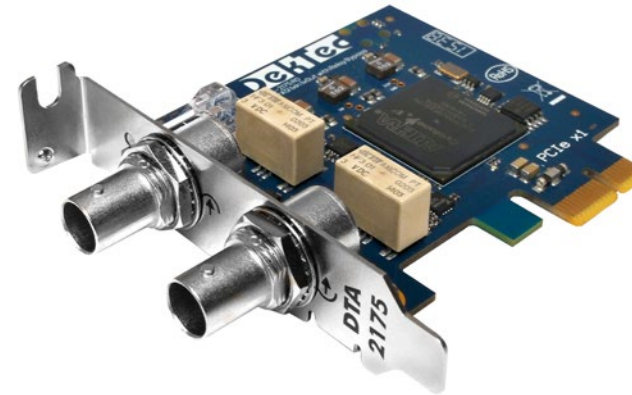

Both ports support HD-, SD-SDI and ASI
Relay bypass for failsafe applications
Efficient access to audio, video and ancillary data

Key Attributes

Parameter	Value
Ports	1 SDI/ASI in, 1 SDI/ASI out
Physical layer	DVB-ASI : EN50083-9 SD-SDI : SMPTE 259M HD-SDI : SMPTE 292M
Connectors	2x 75-Ω BNC
Cable length	ASI – 375m SD-SDI – 375m HD-SDI – 210m
Matrix API 2.0	8/10/16-bit conversion Audio/video/ANC extraction Scaling by 1/4 or 1/16 Access to all 16 audio channels
PCI Express	PCIe2 x1 low profile
OS	Windows 10, 11 Windows Server 16, 19, 22 Linux ≥2.6.18, 3.x, 4.x, 5.x

Related Products

Type	Description
DTA-2145	Dual ASI/SDI Adapter
DTA-2172	Dual 3G-SDI/ASI with Genlock
DTA-2174B	Quad 12G/3G-SDI/ASI with Genlock

Ordering Information

Type	Description
DTA-2175	HD-SDI/ASI input + output with relay bypass for PCIe
DTA-2175-SLP	DTA-2175 with <i>StreamXpress</i> ® and <i>StreamXpert</i> ® Lite

DTA-2178

Octal 12G-SDI/ASI Ports with Genlock

PCI Express

Features

- Each port is fully configurable from software:
 - Input or output
 - ASI or SDI
 - SDI: SD, HD, 3G A+B, 6G, 12GNote: Restrictions apply to configuring 6G and 12G ports
- Bi- and tri-level genlock input port
- Can sustain real-time streaming of two uncompressed 4K UHD streams over 12G-SDI or quad-link
- Monitoring or multiviewing of eight 12G-SDI streams by hardware scaling each channel to 3G-SDI
- Low latency DMA to and from software
- No need to know the low-level structure of SDI, with DekTec Matrix API@ 2.0 you can work directly with audio and video samples, pixel format conversions, ANC data insertion/extraction and video scaling

Applications

- Multi-channel software-based compliance recorders, decoders, encoders, monitors, multiplexers, multiviewers, receivers, stream processors, transcoders, play-out, ...



Eight fully configurable ASI/SDI ports
Monitoring of eight 12G signals by scaling to 3G
Easy access to audio, video and ancillary data

Key Attributes

Parameter	Value
Ports	8 SDI/ASI ports, 1 genlock port
Physical layer	DVB-ASI : EN50083-9 SD-SDI : SMPTE 259M HD-SDI : SMPTE 292M 3G-SDI : SMPTE 424M 6G-SDI : SMPTE 2081 12G-SDI : SMPTE 2082
Connectors	9x 75-Ω micro BNC
Cable length	ASI/SD-SDI 350m HD-SDI 200m 6G SDI 55m 3G-SDI 150m 12G SDI 50m
Matrix API 2.0	8/10/16-bit conversion Audio/video/ANC extraction Scaling by 1/4 or 1/16 Access to all 16 audio channels
PCI Express	PCIe3 x8 low profile
OS	Windows 10, 11 Windows Server 16, 19, 22 Linux ≥2.6.18, 3.x, 4.x, 5.x

Related Products

Type	Description
DTA-2172	Dual 3G-SDI/ASI Ports with Genlock
DTA-2174B	Quad 3G-SDI/ASI Ports (1x12G) with Genlock
DTA-2178-ASI	Octal ASI Ports
DTA-2179	Twelve 3G-SDI/ASI Ports with Genlock

Ordering Information

Type	Description
DTA-2178	Eight 3G-SDI/ASI ports for PCIe
DTA-2178-SXP	DTA-2178 with <i>StreamXpress</i> ®, <i>StreamXpert</i> ®
DTA-2178-SY-SXP	DTA-2178 with <i>SdEye</i> , <i>StreamXpress</i> ®, <i>StreamXpert</i> ®

DTA-2178-ASI

Octal ASI Ports

PCI Express

Features

- Each port is bidirectional and configurable from software as input or output port
- Cable equalization and inverted ASI
- Bitrate measurement and statistics
- Flexible transport-stream receive modes with time-stamping, packet-sequence counting and false-sync pass through for full TR 101 290 support

Applications

- Transport-stream multiplexers and demultiplexers
- Multi-channel monitoring, playout, recording
- ASI-to-IP and IP-to-ASI gateways



Low-cost high-density ASI card
Ideal for (de-)multiplexers, monitoring, gateways

Key Attributes

Parameter	Value
Ports	8 ASI ports
Physical layer	DVB-ASI : EN50083-9
Connectors	8x 75-Ω micro BNC
Cable length	ASI – 350m
PCI Express	PCIe3 x8 low profile
OS	Windows 10, 11 Windows Server 16, 19, 22 Linux ≥2.6.18, 3.x, 4.x, 5.x

Related Products

Type	Description
DTA-2144B	Quad ASI/SD-SDI Ports
DTA-2178	Octal 12G-SDI/ASI Ports with Genlock

Ordering Information

Type	Description
DTA-2178-ASI	Eight ASI ports for PCIe
DTA-2178-ASI-SLP	DTA-2178-ASI with <i>StreamXpress</i> [®] , <i>StreamXpert</i> [®] Lite
DTA-2178-ASI-SXP	DTA-2174B-ASI with <i>SdEye</i> , <i>StreamXpress</i> [®] , <i>StreamXpert</i> [®]

DTA-2179

Twelve HD-SDI/ASI Ports with Genlock for PCIe

PCI Express

Features

- Twelve flexible ports, each independently configurable from software:
 - Input or output
 - HD-SDI, SD-SDI or ASI
 - Up to eight ports 3G-SDI
- Combine HD-SDI and ASI ports in any mix
- Graphics-card class PCI Express gen3 x16 interface avoids bus-bandwidth limitations
- Bi-level and tri-level genlock input port, or digital genlock through port 1
- DekTec Matrix API® 2.0 takes care of all the plumbing for creating robust real-time SDI processing applications.
- Free drivers and SDK (DTAPI) for 32 and 64-bit Windows and Linux

Applications

- Processing UHD signals up to 4Kp50/60
- Monitoring/creating many SDI or ASI signals
- Live production mixer and effect generators
- Image processing with many cameras



High-density HD-SDI/ASI connectivity
High bandwidth: PCIe gen3 x16 interface
Optimized for DekTec Matrix API®

Key Attributes

Parameter	Value
Ports	12 SDI*/ASI ports, 1 genlock port
Physical layer	DVB-ASI : EN50083-9 SD-SDI : SMPTE 259M HD-SDI : SMPTE 292M 3G-SDI : SMPTE 424M 4K : SMPTE 425-5 quad link
Connectors	13x 75-Ω DIN 1.0/2.3
Return loss	≥12dB @ 0 to 3GHz
DekTec Matrix API®	8/10/16-bit conversion Audio/video/ANC extraction Hardware scaling by 1/4 or 1/16 Multiple stream synchronisation
PCI Express	PCIe3 x16
OS	Windows 10, 11 Windows Server 16, 19, 22 Linux ≥2.6.18, 3.x, 4.x, 5.x

* Maximally 8x 3G-SDI simultaneously

Supported Formats

Supported Formats
525i59.94, 625i50
720p23.98, 720p24, 720p25, 720p29.97, 720p30, 720p50, 720p59.94, 720p60
1080p(sf)23.98, 1080p(sf)24, 1080p(sf)25, 1080p(sf)29.97, 1080p(sf)30, 1080i50, 1080i59.94, 1080i60
1080p50, 1080p59.94, 1080p60
2160p50, 2160p59.94, 2160p60

Ordering Information

Type	Description
DTA-2179	Twelve 3G-SDI/ASI ports with genlock for PCI Express
DTA-2179-SLP	DTA-2179 with <i>StreamXpress®</i> , <i>StreamXpert® Lite</i>

The DTA-2179 is still in production but is coming toward the end of its life cycle. Therefore, the DTA 2179 is not recommended for new designs.

DTA-2195

12G-SDI I/O Adapter with HDMI 2.0 Monitor Output

PCI Express

Features

- 12G-SDI input port for ingesting UHD signals up to 4Kp50/60
- 12G-SDI output port with HDMI 2.0 copy for creating UHD signals up to 4Kp50/60
- Bi-level and tri-level genlock input port, or digital genlock through port 1
- PCI Express gen3 four-lane interface for ample bus bandwidth
- Hardware and DekTec Matrix API® 2.0 provide efficient and convenient access to SDI frames:
 - Separation of audio (all channels) and ancillary data
 - On-board 1/4 or 1/16 video scaling for generating previews
 - Sophisticated DMA engine
 - Conversion from and to 16-bit data
- Free drivers and SDK (DTAPI) for Linux and Windows 7/8/10

Applications

- General purpose I/O card for processing 12G-SDI streams in a PC
- ASI/SDI stream station (generator, analyzer) for all SDI rates up 12G-SDI
- 4K software encoder (H.264, HEVC) with 12G-SDI input and ASI output

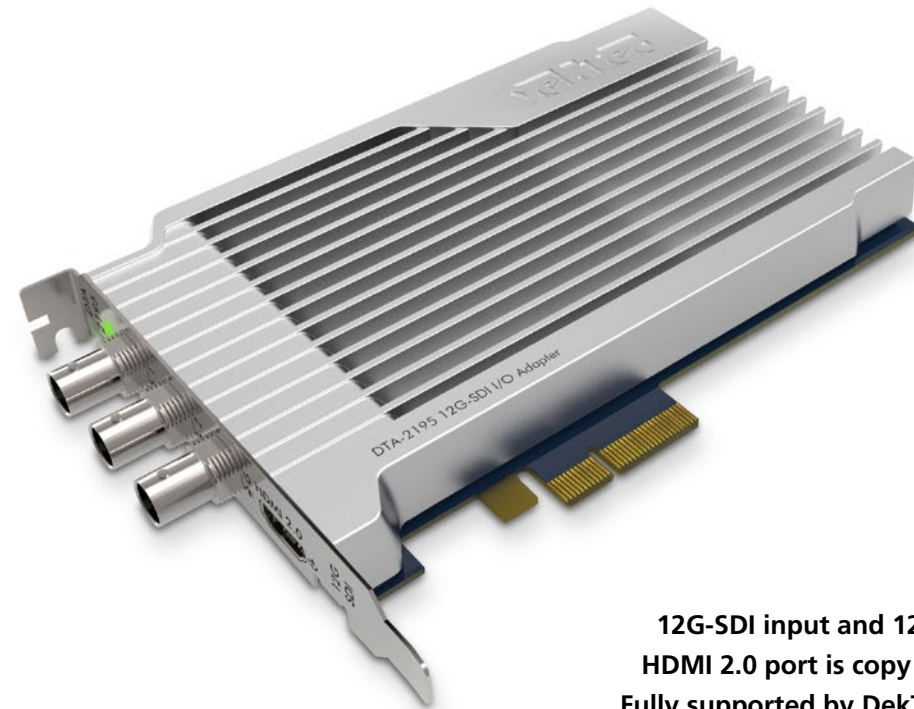

**12G-SDI input and 12G-SDI output port
HDMI 2.0 port is copy of 12G-SDI output
Fully supported by DekTec Matrix API® 2.0**

Key Attributes

Parameter	Value
Ports	1x 12G-SDI input 1x 12G-SDI output 1x HDMI 2.0 output 1x genlock port
Physical layer	DVB-ASI : EN50083-9 SD-SDI : SMPTE 259M HD-SDI : SMPTE 292M 3G-SDI : SMPTE 424M 6G-SDI : SMPTE 2081 12G-SDI : SMPTE 2082
Connectors	3x 75-Ω BNC HDMI type A receptacle
Return loss	≥12dB @ 0 to 3GHz
PCI Express	PCIe3 x4
OS	Windows 10, 11 Windows Server 16, 19, 22 Linux ≥2.6.18, 3.x, 4.x, 5.x

Supported Formats

Supported Formats
525i59.94, 625i50
720p23.98, 720p24, 720p25, 720p29.97, 720p30, 720p50, 720p59.94, 720p60
1080p(sf)23.98, 1080p(sf)24, 1080p(sf)25, 1080p(sf)29.97, 1080p(sf)30, 1080i50, 1080i59.94, 1080i60
1080p50, 1080p59.94, 1080p60
2160p23.98, 2160p24, 2160p25, 2160p29.97, 2160p30
2160p50, 2160p59.94, 2160p60

Ordering Information

Type	Description
DTA-2195	12G-SDI input/output port with HDMI 2.0 monitor output for PCIe
DTA-2195-SXP	DTA-2195 with <i>StreamXpress</i> ®, <i>StreamXpert</i> ®

The DTA-2195 is still in production but is coming toward the end of its life cycle. Therefore, the DTA 2195 is not recommended for new designs.

DTU-215

USB-2 VHF/UHF Modulator

Features

- USB-2 based multi-standard modulator with support for most QAM-, OFDM- and VSB-based modulation standards
- Powered from the USB-2 bus, so no external power adapter is required
- Supports all constellations and modulation modes for each supported standard
- Digital upconversion for excellent signal quality without need for calibration
- Playout of I/Q sample files
- Programmable attenuator
- Free Windows and Linux SDK is fully compatible with other DekTec digital-video output adapters



No power adapter required
Fully agile from 36 to 1002MHz
Channel simulation option

Applications

- Multi-standard test generator
- Demonstrations
- Research and development

Key Attributes

Parameter	Value	
RF connector	75-Ω F male	
Frequency range	36 to 1002MHz ±3ppm	
Bandwidth (max)	8.0MHz	
I/Q sample rate	4.7 to 9.375MHz	
Level	Range	-46 to -15dBm (QAM) -49 to -18dBm (OFDM)
	Step size	0.5dB
	Accuracy	±2dB
MER	>40dB	
Adjacent channel	-54dB (QAM)	
	-52dB (OFDM)	
Phase noise	<-95dBc @ 10kHz	
Spectral purity	>50dB (47 to 1000MHz)	
USB port	USB-2	
Power (through USB-2)	5V, 500mA	
Dimensions (LxWxH)	123 x 62 x 22mm	

Modulation Standards

Modulation	Standard
ATSC VSB	ATSC A/53E
CMMB*	GY/T 220.1/2-2006
DAB+*	EN 300 401
DTMB*	GB 20600-2006
DVB-C	EN 300 429
DVB-C2*	EN 302 769
DVB-T / DVB-H	EN 300 744
DVB-T2*	EN 302 755
I/Q*	Arbitrary I/Q samples
ISDB-T*	ARIB STD-B31
QAM	J.83 Annex A/B/C

* Option

Ordering Information

Type	Description
DTU-215-SP	USB-2 VHF/UHF modulator with <i>StreamXpress</i> ®
DTU-215-GOLD	DTU-215 with all options

DTU-236A

8-VSB/QAM RF Probe with ASI Input for USB-2

Features

- Light-weight, easy-to-use RF adapter for tuning to any UHF/VHF or cable channel in the 45 to 1002MHz range
- Support for all QAM variants
- Extra input for Transport Streams on ASI
- Capture TS signals directly to file on a laptop PC for easy field recording
- Ruggedized portable unit that requires no additional power supply or batteries, operates entirely from a USB-2 connection
- Sensitive front-end allowing reception of RF signals from -30 to +50dBmV
- Combine DTU-236A with RFXpert software for RF measurements, *StreamXpert*® for real-time Transport-Stream analysis
- Channel plans for world-wide regions

RFXpert Measurements

- RF Level, MER, EVM, Constellation, Eye
- BER: Pre/Post FEC, SER (Severe Errored), Errored Seconds
- Channel, Adjacent and Full Spectrum



Receives any UHF/VHF or cable channel
Additional ASI Transport-Stream input
No power supply or batteries required

Key Attributes

Parameter		Value
RF	Connector	75-Ω "F" female
	Frequency range	45 to 1002MHz
	Bandwidth	6/7/8MHz
	Level measurement	-30 to +50dBmV
	Level accuracy	±2dB
	MER range	15 to 38dB
ASI	Connector	75-Ω BNC
	Standard	EN50083-9
	Bit rate	0.5 to 100Mbit/s
Dimensions in mm (LxWxH)		180x107x36
Weight		< 500g

Related Products

Type	Description
DTC-320-SX	<i>StreamXpert</i> ® transport-stream analyzer
DTC-340-RX	RFXpert RF measurement and monitoring software

Ordering Information

Type	Description
DTU-236A-SL	8-VSB / QAM-A/B/C RF probe with <i>StreamXpert</i> ® Lite
DTU-236A-RX	DTU-236A with <i>RFXpert</i>
DTU-236A-SX	DTU-236A with <i>StreamXpert</i> ®
DTU-236A-RSX	DTU-236A with <i>RFXpert</i> and <i>StreamXpert</i> ®

DTU-238

DVB-T2/T/C, ISDB-T and ASI Probe for USB-2

Features

- Light-weight, RF adapter for tuning to any UHF/VHF or cable channel in the 42 to 1002MHz range
- Receiver for DVB-T2, DVB-T, DVB-C2 and ISDB-T
- Extra input for Transport Streams on ASI
- Capture TS signals directly to file on a laptop PC for easy field recording
- Ruggedized portable unit that requires no additional power supply or batteries, operates entirely from a USB-2 connection
- Sensitive front-end allowing reception of RF signals from -40 to +50dBmV
- Combine DTU-238 with RFXpert software for RF measurements, *StreamXpert*® for real-time Transport-Stream analysis
- Channel plans for world-wide regions

RFXpert Measurements

- RF Level, MER, EVM, Constellation, Eye
- BER: Pre/Post FEC, PER (Packet Error Rate), Errored seconds
- Channel, Adjacent and Full Spectrum



DVB-T2, DVB-T, ISDB-T and DVB-C reception
Additional ASI Transport-Stream input
No power supply or batteries required

Key Attributes

Parameter		Value
RF	Connector	75-Ω "F" female
	Frequency range	42 to 1002MHz
	Bandwidth	1.7/5/6/7/8/10MHz
	Input sensitivity	-30 to +50dBmV
	Input return loss	8dB
	MER range	15 to 38dB
ASI	Connector	75-Ω BNC
	Standard	EN50083-9
	Bit rate	0.5 to 100Mbit/s
Dimensions in mm (LxWxH)		180x107x36
Weight		< 500g

Related Products

Type	Description
DTC-320-SX	<i>StreamXpert</i> ® transport-stream analyzer
DTC-340-RX	RFXpert RF measurement and monitoring software

Ordering Information

Type	Description
DTU-238-SL	DVB-T/T2, DVB-C and ASI probe for USB-2 with <i>StreamXpert</i> ® Lite
DTU-238-RX	DTU-238 with <i>RFXpert</i>
DTU-238-SX	DTU-238 with <i>StreamXpert</i> ®
DTU-238-RSX	DTU-238 with <i>RFXpert</i> and <i>StreamXpert</i> ®

DTU-245

FantASI USB-2 ASI/SDI Input+Output Adapter

Features

- Convenient, compact USB adapter that can be used to capture and generate MPEG-2 transport streams (ASI) and uncompressed serial digital video (SDI)
- USB powered - no power supply required
- Independent operation of input and output:
 - Full-duplex: maximum combined bitrate of 160Mbit/s
 - Half-duplex: Full DVB-ASI and SDI bitrate range
- 16-Mbytes local hardware buffer for sustained real-time streaming

Applications

- General-purpose USB adapter for capturing, generating and processing of ASI and SDI streams
- On-site recording and analysis
- Portable demo set

Bundled Software (DTU-245-SXP)

- *StreamXpert*[®] transport-stream analyzer
- *StreamXpress*[®] ASI / SDI player
- Windows/Linux drivers and associated SDK for developing custom applications



No AC power adapter required
Portable streaming of DVB-ASI and SDI
Essential tool for every digital-TV engineer

Key Attributes

Parameter	Value	
Connector	75-Ω BNC (2x)	
ASI	Physical layer	EN50083-9
	Bitrate range	0 to 214Mbit/s*
	Packet size	188 or 204
SDI	Physical layer	SMPTE 259M/C
	Bitrate (half-duplex only)	270Mbit/s
	#Bits	8 or 10 bit
USB port	USB-2**	
Power (through USB-2)	5V, 400mA max	
Dimensions in mm (LxWxH)	87 x 104 x 30	

* 0 to 160 Mbit/s (full-duplex), 0 to 214Mbit/s (half-duplex)

** USB-1 provides insufficient bandwidth and is not supported

Ordering Information

Type	Description
DTU-245-SLP	USB-2 ASI/SDI input+output adapter with <i>StreamXpress</i> [®] and <i>StreamXpert</i> [®] Lite
DTU-245-SXP	DTU-245-SLP with <i>StreamXpert</i> [®]
DTU-245-SY-SLP	DTU-245-SLP with <i>SdEye</i>
DTU-245-SY-SXP	DTU-245-SLP with <i>SdEye</i> and <i>StreamXpert</i> [®]
DTU-245-DVB+	DTU-245-SLP with <i>DVBAnalyzer</i> advanced transport-stream analyser

DTU-315

All-Standard All-Band Modulator for USB-3

USB-3 Adapters

Features

- Pocket-size modulator for satellite, cable and terrestrial standards
- Fully agile from 36 to 2150MHz, covering VHF, UHF and L-band
- Modulation bandwidth up to 70MHz
- Excellent signal quality
- Single USB cable to the DTU-315 supplies power, data and control
- Supports all constellations and modulation modes for each supported standard
- Digital channel simulator option including multipath echo and AWGN
- F and BNC cable assemblies included
- Use with DekTec's *StreamXpress*® for easy generation of RF test signals
- Free Windows and Linux SDK (DTAPI) for writing your own applications

Applications

- RF test generator in your R&D lab or factory for developing, qualifying or repairing any equipment with a DTV antenna input
- Portable demo set for TV receivers, easy to carry to customer demos, trade shows, etc.
- TV transmission or distribution using modulated signals in shops, hotels, hospitals etc.



Key Attributes

Parameter	Value
RF connector	75-Ω micro-BNC female
Frequency range	36 to 2150MHz
Bandwidth (max)	70MHz
I/Q sample rate	0.08 to 70Msps
RF level	Range* -45 to -25dBm
	Step size 0.5dB
MER (typical)	>40dB
Phase noise	<-105dBc @ 10kHz
Spectral purity	>50dB
USB port	USB-3**
OS	Windows 10, 11

* For OFDM standards: up to 1GHz; for single-carrier standards up to 2GHz; above 2GHz the output level is max. 5dB lower.

** Must be a real USB-3 port; the DTU-315 will not operate with USB-2.

Modulator for all popular DTV standards
Fully agile over VHF, UHF and L-band
USB cable supplies power, data and control

Modulation Standards

Standards
ADTB-T*, ATSC, ATSC-M/H*, ATSC 3.0*, CMMB*, DAB(+)*, DMB-T/H*, DVB-C, DVB-C2*, DVB-CID, DVB-S, DVB-S2, DVB-S2X*, DVB-T, DVB-T2 single PLP, DVB-T2 (full)*, I/Q samples*, ISDB-S*, ISDB-S3*, ISDB-T*, ISDB-Tmm*, QAM-B, QAM-C, T-DMB*

* Option

Ordering Information

Type	Description
DTU-315-SP	All-standard all-band modulator for USB-3 with <i>StreamXpress</i> ® player/test-generator software
DTU-315-GOLD	DTU-315 including all current and future modulation options
DTR-315-RACK	1U 19"-rack mounting kit for holding up to 8x DTU 315

DTU-331

Portable All-Standard RF Probe for USB-3

Features

- Fully agile from 42 to 3220MHz, covering VHF, UHF, L-band and a large part of the S-band
- Supports cable, terrestrial and satellite standards
- Tuner, I/Q demodulator and sample-rate converter, optimized for use with SDR technology (Software Defined Radio = demodulation in software)
- Many software demodulators available, including ATSC 3.0 and DVB-T2, with features and measurements exceeding those of consumer demodulator chips
- Hardware sample rate converter for obtaining I/Q samples at a convenient rate
- MER measurements with an accuracy up to 42dB
- Demodulated streams and advanced RF measurements available through free Windows and Linux SDK (DTAPI)
- F and BNC cable assemblies included
- Single USB cable, type-C connectors, supplies power, data and control

Applications

- Portable universal receiver in the lab
- Field measurements with a laptop
- Front end for SDR experiments



Portable SDR receiver for VHF, UHF and L-band
Several software demodulators available, including ATSC 3.0
USB cable supplies power, data and control

Key Attributes

Parameter	Value
RF input connector	75-Ω micro-BNC female
Tuning range	42 to 3220MHz
Input sensitivity	-90 to -20dBm
Input return loss	>10dB @ 0 to 3GHz
I/Q sample size	16-bit I + 16-bit Q
MER measurement	10 to 42dB ±2dB
USB port	USB-3.2 gen 1, type C
OS	Windows 10, 11 Linux ≥2.6.18

Ordering Information

Parameter	Value
DTU-331-XPRT	All-standard SDR receiver with Atsc3Xpert, C2Xpert and T2Xpert
DTU-331-XPRT-SX	All-standard SDR receiver with Atsc3Xpert, C2Xpert and T2Xpert and <i>StreamXpert</i> ®

Modulation Standards

Modulation	Standard
ATSC VSB	ATSC A/53E
ATSC 3.0	ATSC A/322
DAB+	EN 300 401
DVB-C	EN 300 429
DVB-C2	EN 302 769
DVB-T	EN 300 744
DVB-T2	EN 302 755
DVB-S	EN 300 421*
DVB-S2	EN 302 307*
DVB-S2X	EN 302 307-2*
ISDB-T/Tsb	ARIB STD-B31
QAM	J.83 Annex A/B/C

* Please check DekTec website for availability

DTU-351

HD-SDI Input for USB-3

Features

- General purpose HD-SDI input for USB-3
- All 10-bit samples from the full SDI frame can be read
- Supported by DekTec Matrix API® 2.0 to automatically separate HANC, VANC and video
- All 16 audio channels can be read
- Scaling by 1/4 or 1/16 in hardware; scaling factor can be switched on-the-fly
- DirectShow filter available
- Free SDK for easy programmatic access to video, audio channels and auxiliary data

Applications

- With *SdEye*: HD-SDI waveform analysis
- With *VfRec*: HD-SDI full frame recording to hard disk
- Input for DirectShow-enabled applications that process uncompressed video
- HD-SDI input for your application



HD-SDI Interface with full frame access
Hardware scaling to reduce USB bandwidth
Support for HD- and SD-SDI

Key Attributes

Parameter	Value
Physical layer	SD-SDI: SMPTE 259M HD-SDI: SMPTE 292M
Connector	75-Ω BNC
Return loss	≥12dB @ 0 to 1.5GHz
DekTec Matrix API® features	8/10/16-bit conversion Audio/video/ANC extraction Hardware scaling by 1/4 or 1/16 Multiple unit synchronization
USB port	USB-3*
SDK	DTAPI, DekTec Matrix API® 2.0 DirectShow filter
OS	Windows 10, 11 Linux 3.x, 4.x

Supported Formats

Formats
525i59.94, 625i50
720p23.98, 720p24, 720p25, 720p29.97, 720p30, 720p50, 720p59.94, 720p60
1080p(sf)23.98, 1080p(sf)24, 1080p(sf)25, 1080p(sf)29.97, 1080p(sf)30, 1080i50, 1080i59.94, 1080i60

Ordering Information

Type	Description
DTU-351	HD-SDI input for USB-3
DTU-351-SY	HD-SDI input for USB-3 with <i>SdEye</i>
DTU-351-VR-SY	HD-SDI input for USB-3 with <i>VfRec</i> and <i>SdEye</i>

* Must be a real USB-3 port; the DTU-351 will not operate with USB-2

DTE-3100

Networked DVB-ASI Output Adapter

Features

- Standalone module can either be used as compact autonomous TS-over-IP to ASI gateway, or as remote I/O device for PC-based applications
- SMPTE-2022 and DTAPI mode
- Power over Ethernet (PoE) support: No separate power feed required
- External power supply available for use with non-PoE enabled switch
- Advanced time-reconstruction algorithm to overcome IP jitter, with programmable size of jitter-tolerance buffer
- Supports IP decapsulation and 2D FEC decoding according to SMPTE 2022-1 and SMPTE 2022-2
- LCD status display shows device identifier, bitrate, IP/MAC address and status
- Uniform software access to DekTec TS-over-IP-, PCI- and USB devices through DTAPI
- Install up to 12 modules in 3U 19" rack space using the DekTec rack-mountable rail
- Units can be mounted directly on a wall using a DIN rail

Applications

- Autonomous TS-over-IP to DVB-ASI gateway
- With DTE-3120: Tunnelling of ASI signals over LAN, WAN or the Internet
- Remote DVB-ASI output adapter for server-based data inserters, stream servers, multiplexers and similar systems



TS-over-IP to DVB-ASI converter
Power over Ethernet enabled
UDP, RTP, 2D FEC (SMPTE-2022)

Key Attributes

Parameter	Value	
GigE port	Physical layer	IEEE 802.3af
	Data rate	10/100/1000
	Connector	RJ-45
ASI port	Physical layer	DVB-ASI (coax)
	Connector	75-Ω BNC (2x)
	Tx bitrate	0 to 214Mbit/s*
	Resolution	<1bit/s
Transport	TP per IP	1 to 7
	Encapsulation	UDP or RTP
	FEC	SMPTE 2022
TS-over-IP to ASI latency	10ms	
Jitter tolerance range	1 to 120 ms	
DVB ID	5824	

* 209Mbit/s in SMPTE mode

Control

IP-address assignment	DHCP or static
Multicast support	IGMP v2
Device management	Browser based
Network management	SNMP v2c
Discovery	WS-Discovery

Related Products

Type	Description
DTE-3120	Networked ASI input adapter

Ordering Information

Type	Description
DTE-3100	Networked ASI output adapter
DTE-3100-SP	DTE-3100 with <i>StreamXpress</i> ®

Units are shipped with power supply. Add -NOPSU for ordering without power supply

DTE-3114

Networked Quad QAM Modulator

Features

- Standalone four-channel QAM modulator with TS-over-IP inputs and directly synthesized VHF/UHF outputs
- 2D FEC decoder for error correction of incoming TS-over-IP streams
- Web and SNMP interface for setting parameters and observing status
- Unit can be powered via the Ethernet cable (Power over Ethernet) or through a DC power supply jack
- Advanced removal of IP jitter with programmable size of jitter-tolerance buffer
- Full support of SMPTE 2022-1/2
- LCD status display shows device identifier, QAM-mode, carrier frequencies, output level and IP/MAC address
- Install up to 12 modules in 3U 19" rack space using DekTec rack-mountable rail



**Four QAM-A/B/C modulators
Agile over VHF/UHF up to 1GHz
RTP with FEC decoding on each channel**

Applications

- Cable-TV modulator with TS-over-IP input
- QAM test generator

Key Attributes

Parameter	Value	
Main RF port	Connector	75-Ω F Female
	Output level (total)	-32 to -9dBm
Monitor port	Connector	75-Ω F Female
	Output level (total)	-33±3dBm
RF	Range	36 to 1002MHz
	Channel spacing	6 to 8MHz
	Symbol rate	4.48 to 7.0MBd
	MER	42dB
GigE port	Physical layer	IEEE 802.3af
	Connector	RJ-45
Transport	TP per IP	1 to 7
	Encapsulation/FEC	SMPTE 2022
TS-over-IP to QAM latency	10ms (max)	
Jitter tolerance range	1 to 120 ms	

Modulation

QAM-A	EN 300 429 (DVB-C)
QAM-B	J.83 Annex B with support for all interleaver modes
QAM-C	J.83 Annex C

Control

IP-address assignment	DHCP or static
Multicast support	IGMP v2
Device management	Browser based
Network management	SNMP v2c
Discovery	WS-Discovery

Ordering Information

Type	Description
DTE-3114	Networked quad QAM modulator

Units are shipped with power supply. Add -NOPSU for ordering without power supply

DTE-3120

Networked DVB-ASI Input Adapter

Features

- Standalone module can either be used as compact autonomous ASI to TS-over-IP gateway, or as remote I/O device for PC-based applications
- SMPTE-2022 and DTAPI mode
- Time stamping for monitoring applications
- Power over Ethernet (PoE) support: No separate power feed required
- External power supply available for use with a non-PoE enabled switch
- Fail-over relays for input-to-output connection in case of power failure
- Supports IP encapsulation and 2D FEC encoding according to SMPTE 2022-1 and SMPTE 2022-2
- LCD status display shows device identifier, bitrate, IP/MAC address and status
- Uniform software access to DekTec TS-over-IP-, PCI- and USB devices through DTAPI
- Install up to 12 modules in 3U 19" rack space using the DekTec rack-mountable rail
- Units can be mounted directly on a wall using a DIN rail

Applications

- Autonomous DVB-ASI to TS-over-IP gateway
- With DTE-3100: Tunnelling of ASI signals over LAN, WAN or the Internet
- Remote DVB-ASI input adapter for server-based analysers, monitoring applications (Xpect®), multiplexers and similar systems



DVB-ASI to TS-over-IP converter
Power over Ethernet enabled
UDP, RTP, 2D FEC (SMPTE-2022)

Key Attributes

Parameter	Value	
GigE port	Physical layer	IEEE 802.3af
	Data rate	10/100/1000
	Connector	RJ-45
ASI port	Physical layer	DVB-ASI (coax)
	Connector	75-Ω BNC (2x)
	Rx bitrate	0 to 214Mbit/s
	Return loss	17dB typ.
Transport	TP per IP	1 to 7
	Encapsulation	UDP or RTP
	FEC	SMPTE 2022
ASI to TS-over-IP latency	10ms	
Buffer size	32MB	
DVB ID	5823	

Control

IP-address assignment	DHCP or static
Multicast support	IGMP v2
Device management	Browser based
Network management	SNMP v2c
Discovery	WS-Discovery

Related Products

Type	Description
DTE-3100	Networked ASI output adapter

Ordering Information

Type	Description
DTE-3120	Networked ASI input adapter
DTE-3120-SL	DTE-3120 with <i>StreamXpert® Lite</i>
DTE-3120-SX	DTE-3120-SL with <i>StreamXpert®</i>

Units are shipped with power supply. Add -NOPSU for ordering without power supply

DTE-RCK1

19" Mountable Rack for DTE-31XX

- Mount up to 12 DTE-31XX units in a 19" rack
- Mount another 12 units at the back side



DTE-STAND

Table Stand for DTE-31XX

- For non-wall mount applications



DTM-3200

OEM Module TS-over-IP Converter

Features

- Compact OEM module for interfacing a Transport Stream to a network. The DTM-3200 converts from IP to ASI, or from ASI to IP
- Additional 8-bit parallel Transport Stream I/O port on a 26-way boxed header
- Advanced time-reconstruction algorithm to overcome IP jitter, with programmable size of jitter-tolerance buffer
- Full supports of IP encapsulation and 2D FEC encoding/decoding as described in SMPTE 2022-1/2
- Unicast and multicast IP addressing
- Various serial interfaces available for controlling the OEM module
- Persistent storage of configuration parameters

Applications

- Easy way to add a TS-over-IP input or output to your TS-processing product
- Tunnelling of ASI signals over LAN, WAN or the Internet

Development Kit

- DTM-3200 module
- Power supply with cable
- USB to serial converter

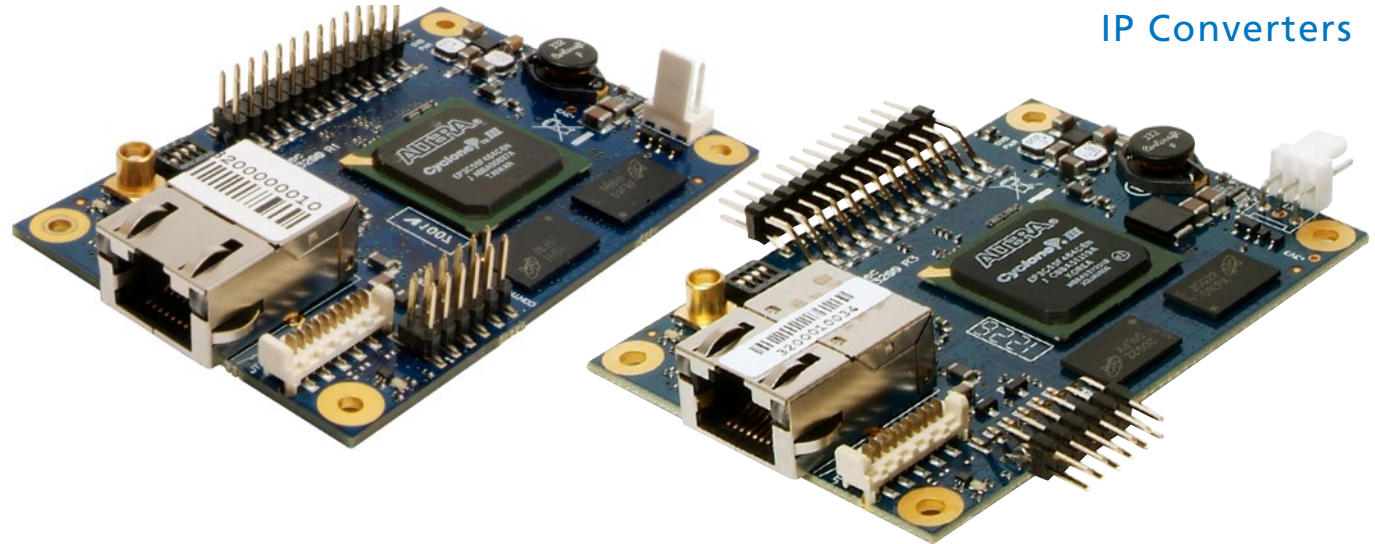

Converts ASI to IP or IP to ASI
Serial and parallel TS port
UDP, RTP, 2D FEC (SMPTE-2022)

Key Attributes

Parameter		Value
GigE port	Physical layer	IEEE 802.3a
	Data rate	100/1000
	Connector	RJ-45 with LEDs
DVB-ASI port	Physical layer	EN50083-9
	Connector	1x 75-Ω MCX
	Tx bitrate	0.01 to 214Mbit/s
Parallel port	Physical layer	M-LVDS
	Signals	Clock, sync, valid, 8-bit data
	Connector	26-way header
Transport	TP per IP	1 to 7
	Encapsulation	UDP or RTP
	FEC	SMPTE 2022
TS-over-IP to ASI latency*		1ms
Jitter tolerance range		1 to 500ms
Dimensions WxHxD		80x55x14mm

* Excluding FEC reconstruction and jitter tolerance delay.

IP Protocol Support

Encapsulation	IEEE 802.2 SNAP, Eth. II
IP support	IPv4
IP-address assignment	DHCP, link local or static
Multicast support	IGMP v2
Device management	Out of band: RS-232, RS-422, RS-485, I2C
Network management	Not supported

Related Products

Type	Description
DTE-3100	Networked ASI output (DIN-rail mount)
DTE-3120	Networked ASI input (DIN-rail mount)

Ordering Information

Type	Description
DTM-3200	OEM TS-over-IP converter
DTM-3200-RA	DTM-3200 with right-angle connectors
DTM-3200-DEVKIT	Development kit for DTM-3200

DTM-3224

Standalone OEM Module Quad ASI to IP Converter

Features

- Compact OEM module for interfacing four ASI transport streams to an IP network
- Encoding and insertion of 2D FEC packets as defined in SMPTE 2022-1
- IP encapsulation with UDP and RTP support according to SMPTE 2022 2
- Unicast and multicast IP addressing
- IPv4 or IPv6
- Supports source-specific multicast
- Choice of three serial control interfaces:
USB 2.0, true RS-232 or I2C
- Persistent storage of configuration parameters in on-board flash memory
- Mounting compatible to DTM-3200

Applications

- Tunnelling of ASI transport streams over LAN, WAN or the Internet



Quad ASI to Gigabit Ethernet conversion
Serial control over USB, I²C or RS-232
UDP, RTP, 2D FEC (SMPTE-2022)

Key Attributes

Parameter		Value
GigE port	Physical layer	IEEE 802.3a
	Data rate	100/1000
	Connector	RJ-45 with LEDs
ASI ports	Number of ports	4
	Physical layer	EN50083-9
	Connector	4x 75-Ω MCX
	Bitrate per port	0.1 to 214Mbit/s
	Max. total bitrate	700Mbit/s
Transport	TP per IP	1 to 7
	Encapsulation	SMPTE 2022-2
	FEC	SMPTE 2022-1 up to 20x20
Power supply requirement		12V±10%
Dimensions WxHxD		80x55x14mm

IP Protocol Support

Ethernet encapsulation	IEEE 802.2 SNAP, Eth. II
IP support	IPv4, IPv6
IP-address assignment	DHCP, DHCPv6, link local or static
Multicast support	IGMP v3, MLDv2
Device management	Out of band: RS-232, USB 2.0, I2C
Network management	Not supported

Ordering Information

Type	Description
DTM-3224	OEM Quad ASI to IP converter
DTM-3224-DEVKIT	Development kit for DTM-3224

DTM-3237

OEM DVB-S/S2/S2X Receiver with ASI Output

Features

- Compact OEM module for receiving DVB-S/S2/S2X and outputting it as DVB-ASI
- All DVB-S2 modulation types can be demodulated: QPSK, 8PSK, 16/32APSK
- Supports advanced DVB-S2 features including VCM, ACM, Multiple Input Streams (MIS) and Generic Stream (GS)
- Reception and forwarding of transport streams
- Extraction of Satellite Delivery System Descriptor information such as Orbital position and Polarization
- Full LNB support with DiSEqC interface and 13V/14V/18V/19V 500mA supply
- Signal quality indicators include lock status, RF level, modulation type, code rate, BER, MER
- Serial control of the OEM module through USB and I2C
- Persistent storage of configuration parameters

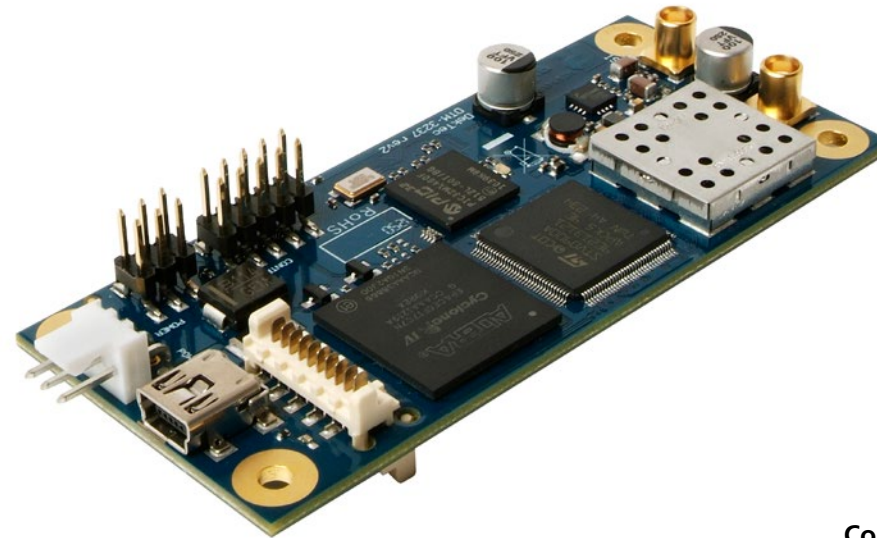

Converts DVB-S2 to DVB-ASI
Compact and low-cost OEM module
Supports 32APSK, MIS, GS, VCM, ACM

Applications

- Low-cost receiver module for satellite to cable transcoders
- Satellite data distribution
- Monitoring of satellite signal quality
- In combination with DTM-3200: DVB-S2 (or DVB-S) to TS-over-IP conversion

Key Attributes

Parameter	Value	
Antenna input	75-Ω MCX Female	
Input return loss	>9dB @ 1 to 2GHz	
Tuning range	950 to 2150MHz	
Input sensitivity	-60 to -30dBm	
Baud rate	2 to 45MBd	
Modulation standard	DVB-S2, DVB-S	
Metrology	RF level	-60 to -30dBm ±5dB
	MER	0 to 22dB ±2dB
	BER (DVB-S)	Pre Viterbi; Pre RS
	BER (DVB-S2)	Pre/Post LDPC & BCH
LNB supply	13V/14V/18V/19V 500mA	
DVB-ASI port	Physical layer	EN50083-9
	Connector	75-Ω MCX Female

Related Products

Type	Description
DTM-3200	OEM module for conversion between ASI and TS-over-IP
DTA-2107	DVB-S/DVB-S2 modulator with L-band upconverter for PCIe
DTA-2137C	DVB-S/S2 receiver for PCIe
DTE-3137	Standalone DVB-S/S2 receiver with ASI and TS-over-IP output

Ordering Information

Type	Description
DTM-3237	OEM DVB-S2 receiver with DVB-ASI output
DTM-3237-DEVKIT	Development kit for DTM-3237

StreamXpress®

Transport-Stream/SDI Playout Software

Features

- Integrate yourself a low-cost, high-performance stream player using a standard- or industrial PC, a DekTec output adapter and the *StreamXpress®* playout software
- Test-signal generator includes UHD 4K moving test pattern
- Integrated (P)SI viewer
- Control of modulation parameters
- Optional channel modeling of RF output signal
- Supports DVB-CID configuration
- Integrated ISDB-T hierarchical multiplexer
- Supports ATSC.3.0 STLTP playback
- Play-out at a higher rate by null-packet stuffing with PCR correction
- Endless play with optional automatic correction of continuity-counter and PCR/PTS/DTS fields
- Automatic computation of transport rate
- Reproducible injection of errors in the transport stream with adjustable error rate
- SOAP-based remote control option

Applications

- Universal MPEG-2 stream generator for feeding set-top boxes, digital-video processing equipment, etc.
- Demoing your MPEG-2 equipment
- Laboratory MPEG-2 test-signal generator

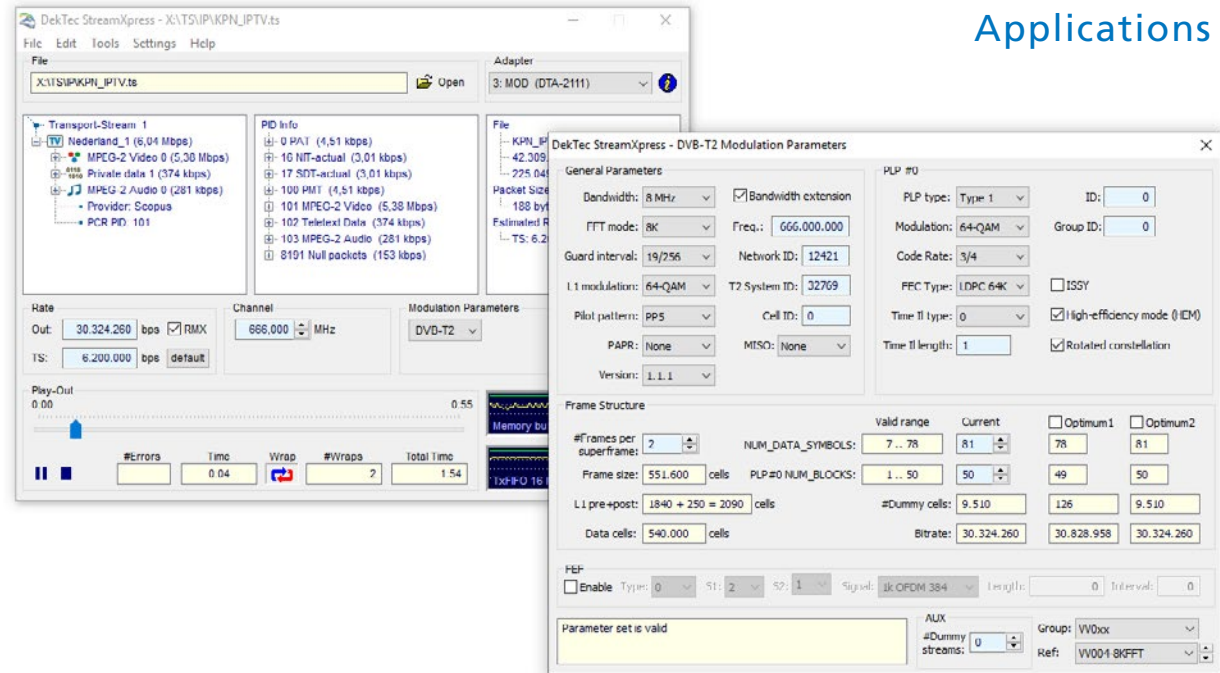

Industry-standard player
Selective error injection
Integrated (P)SI viewer, looping

Supported Output Adapters

Signal Type	Supported Adapters
DVB-ASI	DTA-2136, 2127, 2142, 2144B, 2145, 2160, 2172, 2174(B), 2175, 2178, 2178-ASI, 2179, 2195 DTE-3100, DTU-245
HD-SDI	DTA-2127, 2172, 2174(B), 2175, 2178, 2179, 2195
3G-SDI	DTA-2172, 2174(B), 2178, 2179, 2195
4K UHD	DTA-2174(B), 2178, 2179, 2195
Modulators	DTA-2107, 2111, 2115B, 2116 DTU-215, 315
TS-over-IP	DTA-2110, 2160, 2162 Local NIC

PC Requirements

Platform	Windows 10, 11
Processor*	Core i5 minimum, core i7 recommended

* Or equivalent AMD processor

Ordering Information

Type	Description
DTC-300-SP	<i>StreamXpress®</i> playout software
DTC-300-DGL	<i>StreamXpress®</i> license on a USB dongle for local NIC playout
DTC-302-RC	Remote control option
DTC-305-CM	<i>XpressSim</i> channel-modelling option for modulators

StreamXpert® v2

Real-Time Stream Analyzer Software

Features

- Real-time and offline analysis of transport streams with intuitive user interface
- Provides detailed statistics on PIDs, services and tables found in the transport stream
- Deep decoding of PSI, DVB-SI, DVB-RCS and ATSC-PSIP tables and descriptors
- User-definable TR 101 290 templates
- Analysis of ATSC3.0 MMT, ROUTE, ALP streams and PCAP files with table and AV attributes display
- OTT analysis mode: HTTP Smooth Streaming and MPEG-DASH manifest visualisation and decoding
- Integrated video decoder for MPEG-2 video, AVC/H.264, AVS and HEVC/H.265, with support for 4:2:2 and 10-bit video
- Integrated audio decoder with support for MPEG-1 layer II, (HE-)AAC, Dolby Digital (AC3), AC4 and MPEG-H
- Analysis of TS-over-IP streams via a DTA-2110, DTA-2160, DTA-2162 and PC NIC card
- Decoding and display of closed captions
- Teletext decoding

Applications

- The world's most cost-effective and user-friendly transport-stream analyzer
- Test and validation of equipment with transport-stream output, e.g. multiplexers
- Quality monitoring of MPEG-2 transport streams in studios, head ends, etc.

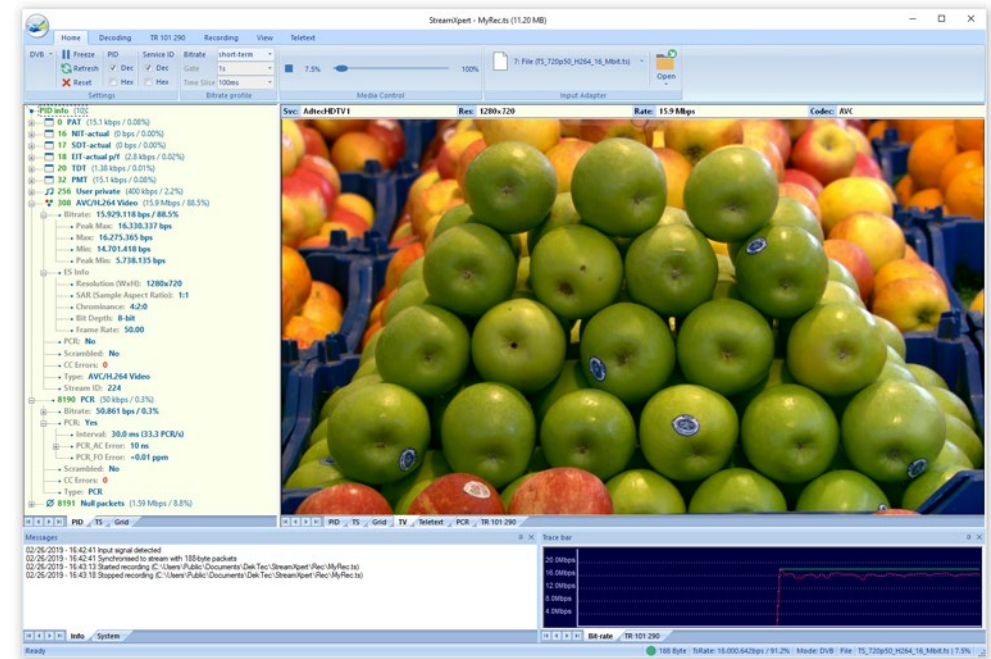

Supported Input Adapters

Signal Type	Supported Adapters
DVB-ASI	DTA-2142, 2144B, 2145, 2160, 2172, 2174(B), 2175, 2178, 2178-ASI, 2179, 2180 DTE-3120, DTU-225, 245
Receivers	DTA-2127, 2131, 2132, 2136, 2137C, 2138B, 2139B/C DTU-236A, 238, 331, DTE-3137
TS-over-IP	DTA-2160, 2162, DTA-2110, 2160, 2162, PC NIC

PC Requirements

Platform	Windows 10, 11
Processor*	Core i7 (4K decoding)

* Or equivalent AMD processor

Related Products

Type	Description
DTC-335-SY	SdEye SDI analysis software
DTC-720-XP	Xpert® transport-stream monitoring

Ordering Information

Type	Description
DTC-320-SX	StreamXpert® transport stream analyzer
DTC-320-NIC	StreamXpert® for PC NIC (dongle)
DTC-320-SXDGL	StreamXpert® license on a USB dongle
DTC-321-SL	StreamXpert® Lite (-SL option)
DTC-3201-1YR	1 year software maintenance for StreamXpert® v2

SdEye

Real-Time SDI Waveform Monitor

General Features

- Real-time waveform analyser for SD- and HD-SDI signals
- Support for 4K video
- Contemporary GUI with quick access buttons
- Support for .dtsdi file input
- EDH/CRC error detection
- SDI data logging to a CSV log file

Picture Display

- Top, bottom, interlaced, full frame
- Separate Y, Cb, Cr or RGB channel display

Waveforms

- Y,Cb,Cr or RGB graphs
- Vectorscope
- Single line selection

Audio

- Audio decoding/display
- Peak meter (up to 16-channel display)
- Stereoscope

SDI Ancillary Data

- List of all ancillary data streams
- Display of SDI data words with user selectable row and column
- Hex or decimal, 8 or 10-bit display
- Teletext decoding
- EIA 608/708 closed captions decoding
- Freeze frame trigger on SCTE-104 flags

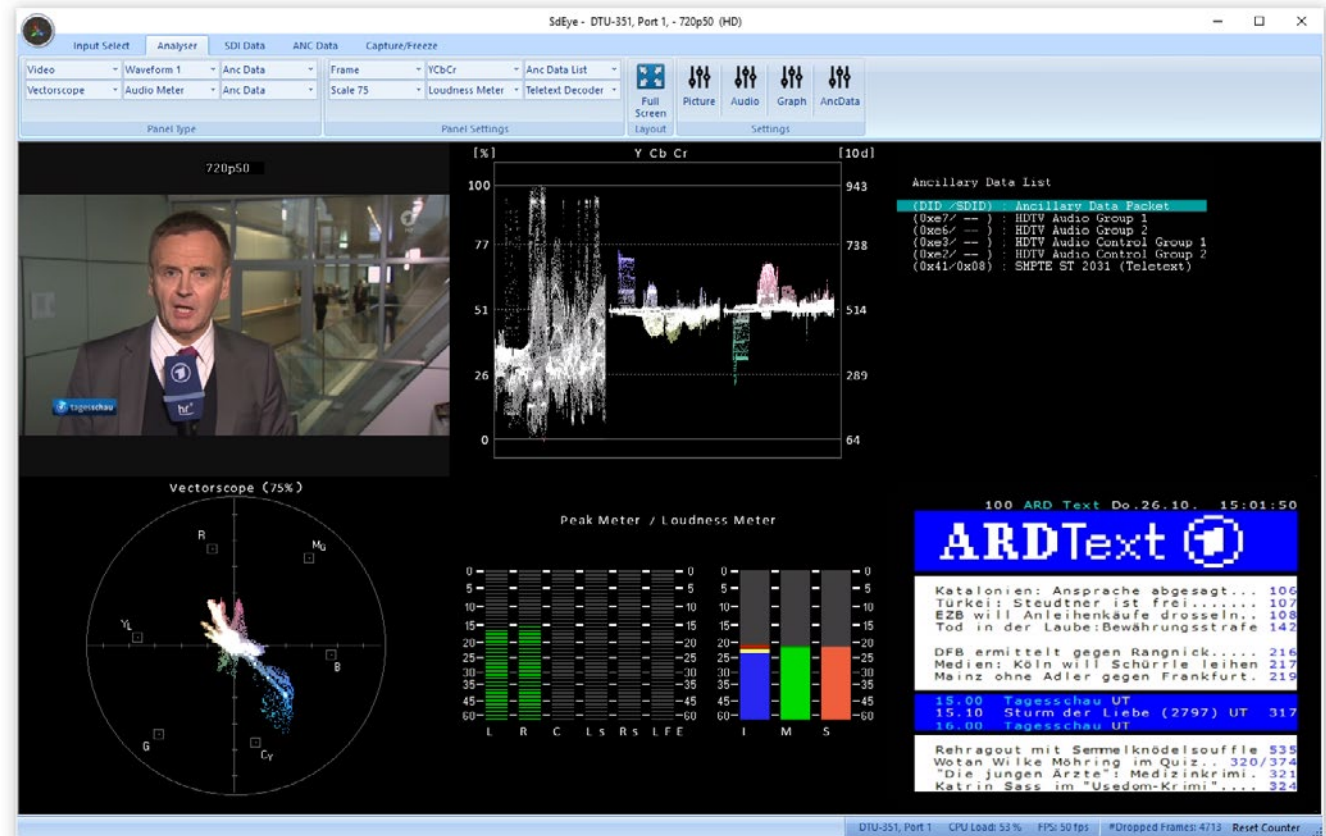

Key Attributes

Parameter	Value
Input signal	SD-SDI: SMPTE 259M HD-SDI: SMPTE 292M 3G-SDI: SMPTE 424M 12G-SDI: SMPTE 2082

PC Requirements

Platform	Windows 10, 11
Processor*	Core i7 minimum

* Or equivalent AMD processor

Supported Input Adapters

Bus	Supported Adapters
PCI Express	DTA-2110, 2127, 2144B, 2145, 2160, 2172, 2174(B), 2175, 2178, 2179, 2195
USB	DTU-225, 245, 351

Ordering Information

Type	Description
DTC-335-SY	SdEye SDI Waveform Monitor

Atsc3Xpert, T2Xpert, C2Xpert

Analysis Software for ATSC 3.0, DVB-T2, DVB-C2

Features

- Real-time reception and analysis of ATSC 3.0, DVB-T2 or DVB-C2
- Displays a comprehensive overview of signaling info
- Outputs a demodulated stream over IP
- Uses the DTA-2131 or DTU-331 SDR receivers
- Measures RF level, C/N, MER and BER
- Gathers statistics about number of LDPC iterations required to correct all errors and displays LDPC iterations history in a graph
- Advanced statistics including constellation per PLP, impulse response and transfer-function graphs

Applications

- Measurement and analysis of all aspects of ATSC 3.0, DVB-T2 and DVB-C2 signals
- Demonstrations and field trials

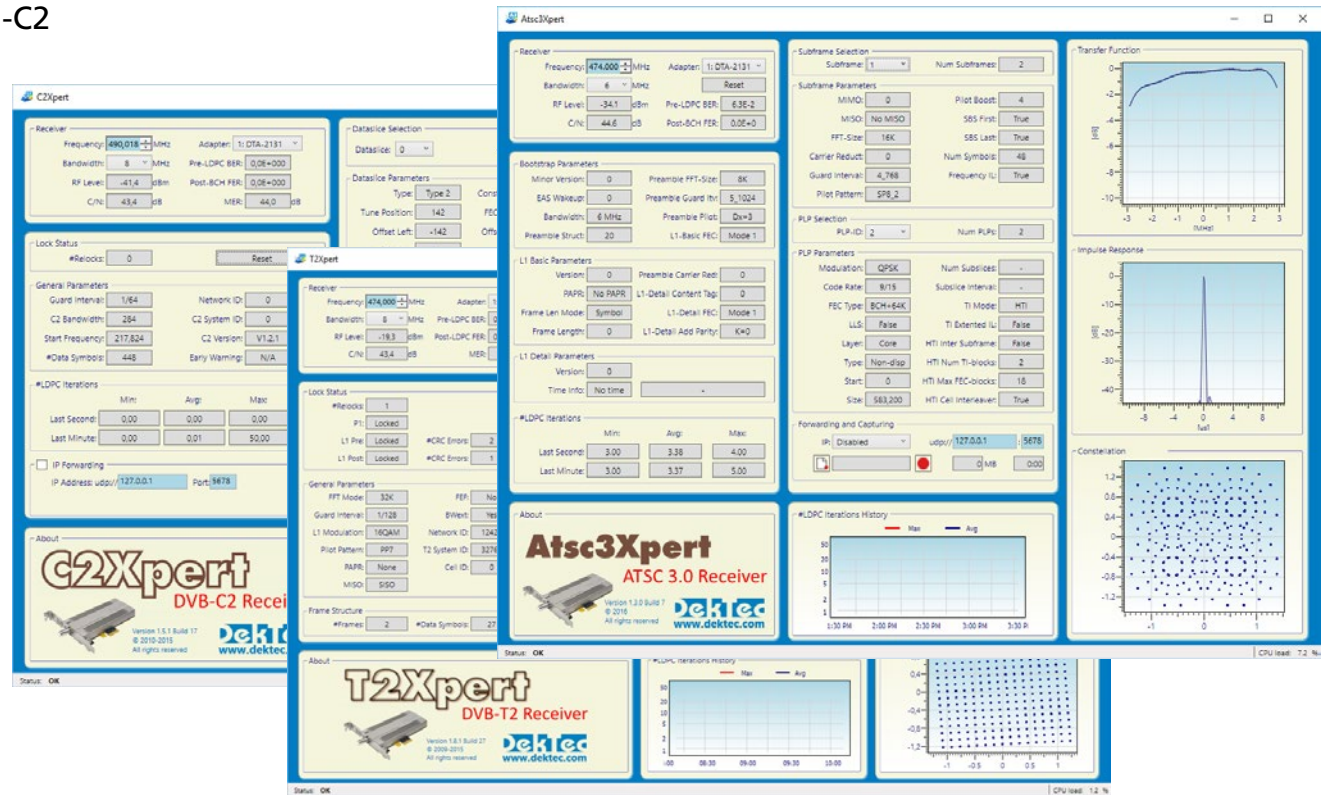

Atsc3Xpert Key Attributes

Standard	ATSC 3.0 A/322
Bandwidth	6, 7, 8 MHz
Fields in GUI	RF level, C/N, BER, MER, Lock status, Bootstrap parameters, L1 basic parameters, L1 detail parameters, Subframe parameters, PLP parameters, LDPC iterations
Graphs in GUI	Transfer function Impulse response Constellation
Data output	PCAP IP-capture file ALP, ROUTE/MMP over IP

T2Xpert Key Attributes

Standard	DVB-T2, EN 302 755 T2-MI, ETSI TS 102 733
Bandwidth	1.7, 5, 6, 7, 8 MHz
Fields in GUI	RF level, C/N, BER, MER, Lock status, General parameters, PLP parameters, LDPC iterations
Graphs in GUI	Transfer function, Impulse response, Constellation
Data output	TS over IP, TS-MI over IP

PC Requirements

Platform	Windows 10, 11
Processor	Core i7 4th gen. minimum

C2Xpert Key Attributes

Standard	DVB-C2, EN 302 769
Bandwidth	6, 8 MHz
Fields in GUI	RF level, C/N, BER, MER, Lock status, General parameters, Dataslice parameters, PLP parameters, LDPC iterations
Graphs in GUI	Transfer function, Impulse response, Constellation
Data output	TS over IP

Ordering Information

Type	Description
DTA-2131-XPRT	Multi-standard VHF/UHF receiver with Atsc3Xpert, C2Xpert and T2Xpert

Atsc3Xpress, T2Xpress, C2Xpress

Signal Generator Software for ATSC 3.0, DVB-T2, DVB-C2

Features

- Complete multi-PLP modulator with file input and live IP input (Atsc3Xpress only)
- RF output, using DTA-2115B, DTA-2116 or DTU-315
- With DekTec's DTC-371-IQ option:
 - Offline generation of I/Q sample files
- Full user control over general, per-PLP and modulation-standard specific parameters
- Built-in O151 PRBS test-signal generator
- Can be used in conjunction with DekTec's DTC 305-CM XpressSim channel simulator with AWGN generator (adjustable SNR), multipath fading to accurately simulate reflections

Applications

- General-purpose test-signal generator for ATSC 3.0, DVB-T2 or DVB-C2
- Receiver chip development, testing and evaluation
- Demonstrations and field trials

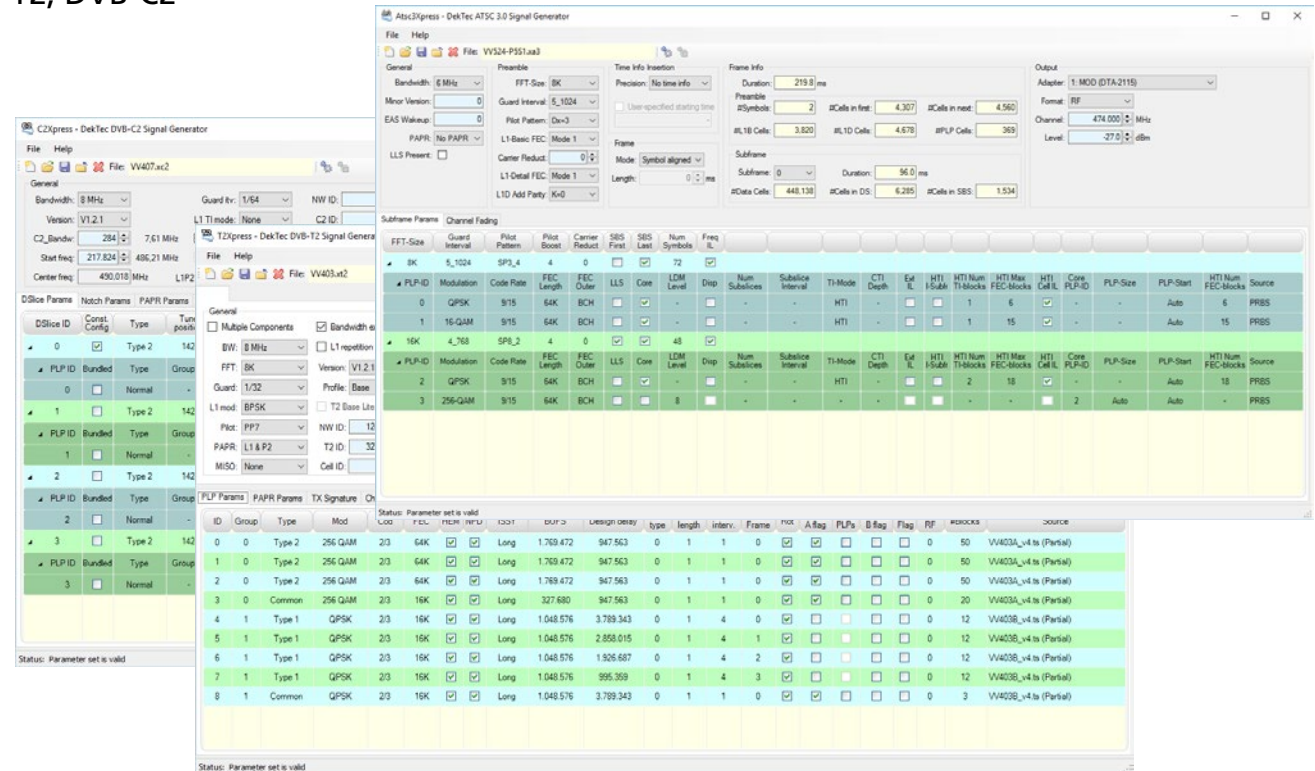

Supported Output Adapters

Type	Description	ATSC3	T2&C2
DTA-2111	Multi-standard VHF/UHF modulator for PCIe		Y
DTA-2115B	All-standard VHF/UHF/L-band modulator for PCIe	Y	Y
DTA-2116	All-Standard 0-3GHz Modulator for PCIe	Y	Y
DTU-215	Multi-standard VHF/UHF modulator for USB-2		Y
DTU-315	All-standard all-band modulator for USB-3	Y	Y

PC Requirements

Platform	Windows 10, 11
Processor	Core i7* recommended

* Or equivalent AMD processors.

Ordering Information

Type	Description
DTC-386-ATSC3	Atsc3Xpress ATSC 3.0 signal generator
DTC-378-T2	T2Xpress DVB-T2 signal generator
DTC-379-C2	C2Xpress DVB-C2 signal generator
DTC-305-CM	XpressSim channel-modelling option
DTC-371-IQ	I/Q sample generation option

TmmXpress

ISDB-Tmm Signal Generator Software

Features

- Complete ISDB-Tmm, TsB or T modulator compliant to ARIB STD-B46, with file input and RF output on e.g. DTA-2111
- 14.5MHz bandwidth (33 segments) on DTA-2111 or DTA-2115B
- With DekTec's DTC-371-IQ option: Off-line generation of I/Q sample files
- Full user control over all ISDB parameters
- Input from Transport-Stream files
- Can be used in conjunction with DekTec's DTC-305-CM XpressSim channel simulator with AWGN generator (adjustable SNR), multipath fading to accurately simulate reflections

Applications

- Test-signal generator for ISDB-T receiver chip development, testing and evaluation
- Signal generator for ISDB-Tmm demonstrations and field trials

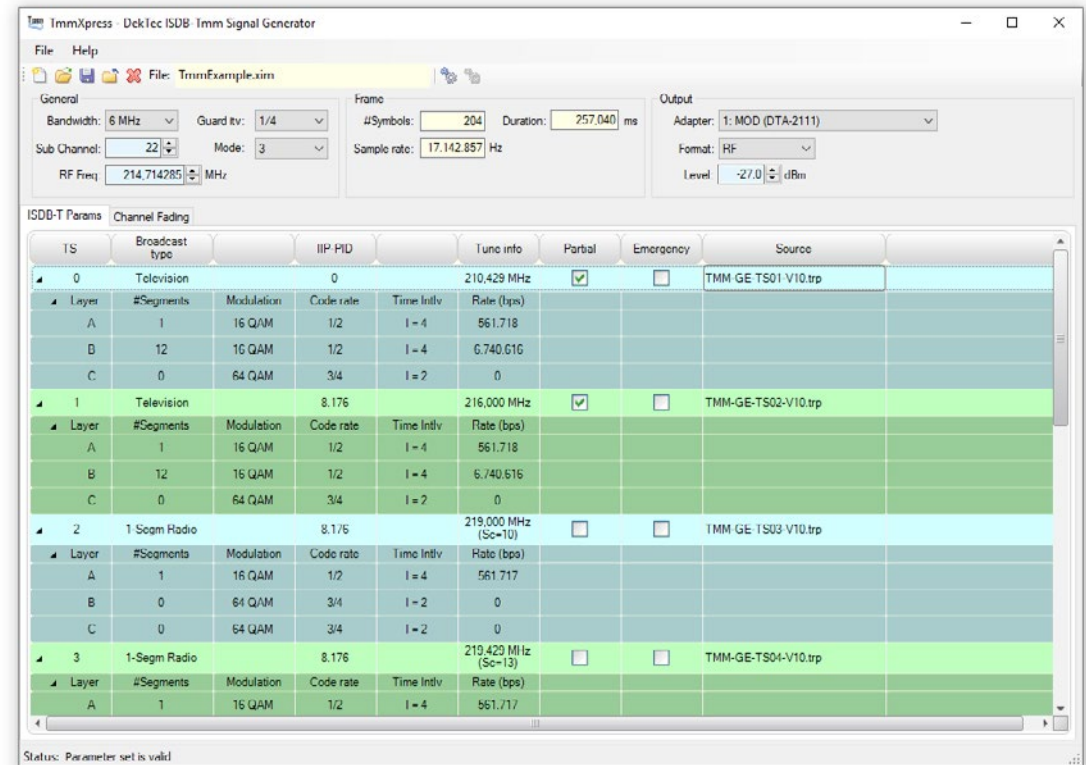

Key Parameters

Parameter	Range
Bandwidth	6, 7, 8, 14.5MHz
Guard interval	1/4, 1/8, 1/16 or 1/32
Mode	1 (2k), 2 (4k) or 3 (8k)
Sub channel	0 to 42
Broadcast type	TV, 1-seg or 3-seg radio
IIP PID	PID of the IIP
#Segments	0 to 13
Modulation	DQPSK, QPSK, 16- or 64-QAM
Code rate	1/2, 2/3, 3/4, 5/6, 7/8
Interleaving	0, 1, 2, 4, 8, 16
I/Q format*	Float32, Int16, Text
Real time output	ISDB-Tmm, TsB, T

* I/Q format requires the DTC-371-IQ option

Related Products

Type	Description
DTA-2111	VHF/UHF modulator for PCIe
DTA-2115B	VHF/UHF/L-Band modulator for PCIe
DTC-300	StreamXpress® playout software
DTC-305-CM	XpressSim channel-modelling option
DTC-371-IQ	I/Q sample generation option
DTC-380-16MHZ	16-MHz bandwidth option

Ordering Information

Type	Description
DTC-382-TMM	TmmXpress ISDB-Tmm signal generator software

MuxXpert

Real-Time Multiplexer

Features

- Real-time multiplexing and re-multiplexing of live transport streams
- Integrated file players for the insertion of local content from disk into live streams
- Allows re-multiplexing of services and service components from any input to any output
- Automatic PSI and DVB-SI extraction, re-generation and insertion
- Recording of output transport stream
- Monitoring, control and programmatic access to the configuration through the *MuxXpert API*
- Runs on a standard- or industrial PC with all DekTec input and output adapters
- Flexible configuration allows adaptation of PIDs, services, tables, descriptors, etc.
- User interface provides information about services, components and bitrates in the input and output transport streams

Applications

- Master and head-end (re-)multiplexing
- Local program insertion
- Generating transport-stream bouquets
- Creation of fully customized transport streams from files and live feeds

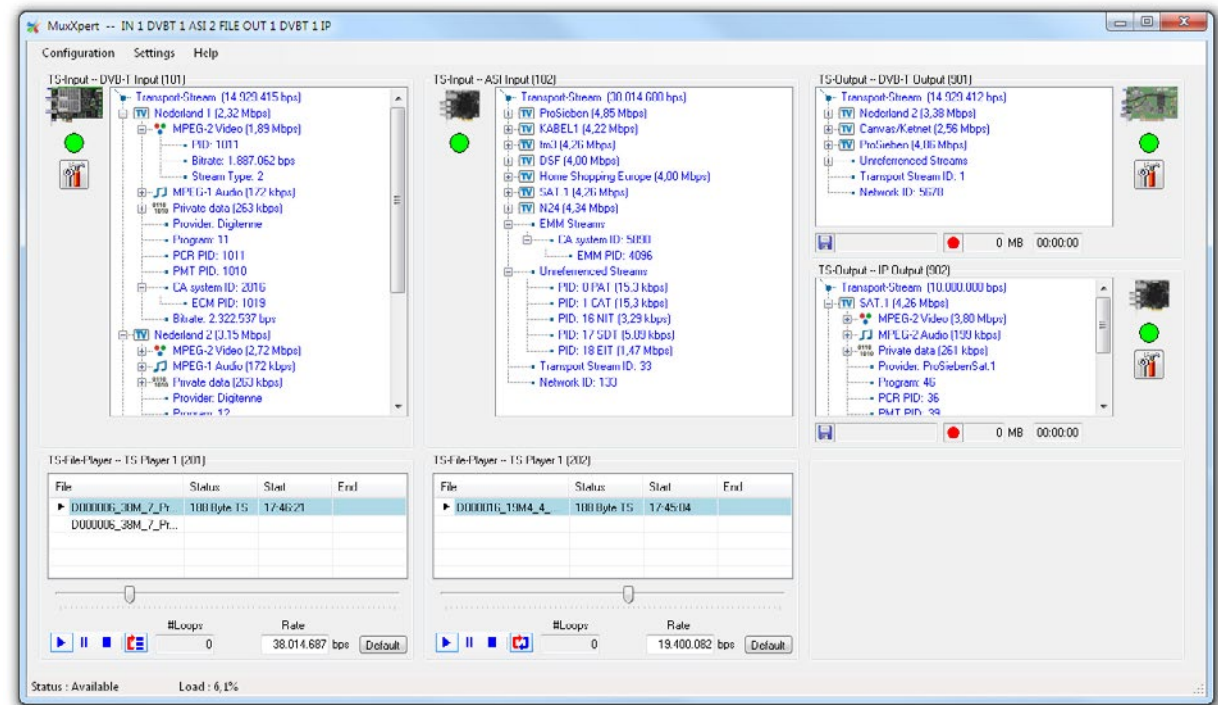

Key Attributes

Parameter	Value
Number of TS inputs	0 to 64*
Number of TS outputs	1 to 64*
Number of file players	0 to 32*
Sum of input rates	0 to 300Mbit/s
Sum of output rates	0 to 300Mbit/s

* Not all combinations are allowed and depend on CPU speed and RAM. A limited number of channels are shown in the UI.

PC Requirements

Platform	Windows 10, 11
Processor*	Core i5, i7

* Or equivalent AMD processor

Supported I/O Adapters

Bus	Types
PCI Express	DTA-2107, 2110, 2111, 2115B, 2127, 2131, 2132, 2136, 2137C, 2138B, 2139B/C, 2144B, 2145, 2152, 2160, 2162, 2172, 2174(B), 2175, 2178, 2179, 2180, 2182, 2195
USB	DTU-215, 315, 331, 245*
IP	DTE-3100, 3120, Local NIC

* For evaluation and demos, not recommended for operational use.

Ordering Information

Type	Description
DTC-700-MX	<i>MuxXpert</i> MPEG-2 multiplexer
DTDONG-1-MX	<i>MuxXpert</i> license on a USB dongle*

* For using MuxXpert with DTE-3100/3120 and/or local NIC.

Features

- Simultaneous monitoring of multiple transport streams
- Mosaic multi viewer included, see DTC-720 Xpect® Mosaic
- Web interface supports live video and audio decoding
- Full TR 101 290 conformance testing
- Freeze frame, black frame, audio silence detection
- Template Matching: Checks properties of services, service components and tables
- Capturing of the monitored transport stream to a file, with pre- and post-trigger buffer, client initiated or triggered by a TR 101 290- or template violation
- Maintains detailed statistic information about bitrates, PCR and IP jitter and packet loss
- Can be integrated with 3rd party monitoring systems for 24/7 network supervision
- SOAP and SNMP interface for remote control and automated access to statistics and error-event database
- Web interface for remote configuration and access to event log and statistic information
- Includes configuration tool for easy creation of templates and TR 101 290 profiles
- Forwarding of transport stream over IP for remote real-time analysis or viewing
- Template matching for DVB/teletext subtitles, closed captioning and SCTE-35
- Export event log to a CSV file

Applications

- 24/7 Network supervision
- Automated equipment test and validation

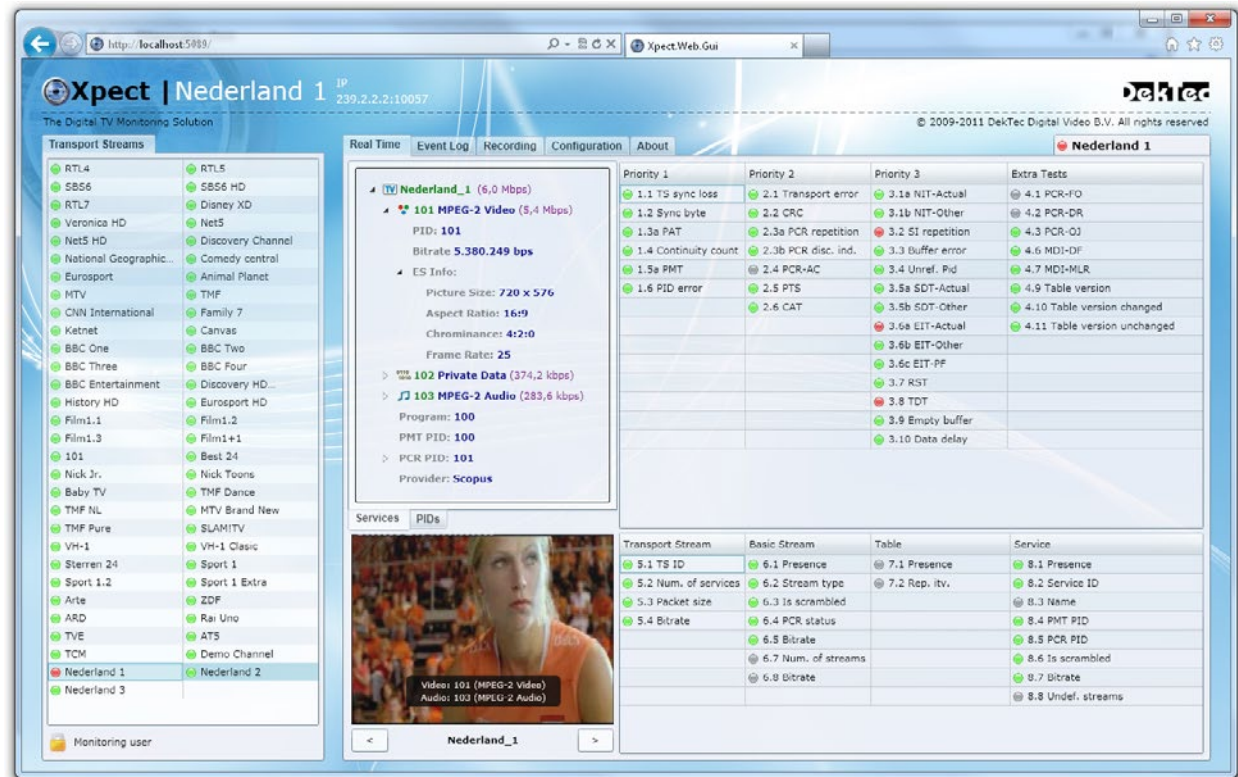

Supported Input Adapters

Signal Type	Supported Adapters
ATSC 8VSB	DTA-2131, 2139C
DVB-ASI	DTA-2144B, 2145, 2152, 2160, 2172, 2174(B), 2175, 2178, 2179 DTE-3120, DTU-225*, 245*
DVB-S/S2	DTA-2127, 2132, 2137C, DTE-3137
DVB-T/T2/C/C2	DTA-2138B, 2139B/C
ISDB-T	DTA-2131, 2139B/C
QAM	DTA-2136, 2139B/C
TS-over-IP	DTA-2110, 2160, 2162 Local NIC

* For evaluation and demos, not recommended for operational use

Key Attributes

Parameter	Value
Typical #TS that can be monitored	40 MPTS @ 40Mbit/s 250 SPTS @ 6Mbit/s
Platform	64-bit Windows 2k8, 2k12, 2k16, 2k19, 10, 11

Ordering Information

Type	Description
DTC-720-nPT	Xpect® monitoring, n points*
DTC-720-DGL nPT	n points* on a dongle
DTC-7201-YR	1 year of software maintenance

* Each SPTS Video requires 1/2 point; each SPTS Audio requires 1/4 point, each MPTS requires 4 points

Features

- Creates an easy-to-oversee mosaic of decoded video, sub titles, audio bars and monitoring status
- Software-based solution that runs on standard PC hardware
- Supports MPEG-2 and AVC video, SD and HD
- Loudness indicators compliant to EBU R 128
- Multiple subtitles support for DVB, Teletext and CC
- Picture cells with custom contents
- Customisable clock
- Alarms from the Xpect® monitoring core can be visualized in the mosaic using LED indicators or a red border
- Customisable XML templates to change size and position of each display element, as well as colours, text font, etc.
- Supports multiple DekTec input devices to combine e.g. ASI and IP inputs
- Graphics card acceleration
- HDMI/DVI/xVGA output using standard PC graphics card
- Support for multiple mosaic screens
- Remote configuration tool for easy definition and uploading of a mosaic
- Predefined mosaic layout or fully customisable using 'drag and drop'
- Dynamic mosaic updates using SOAP interface, like service switching and text overlay

Applications

- Control room monitoring
- Impressive display of the services generated or received in your facility
- Fully customisable OEM multi viewer

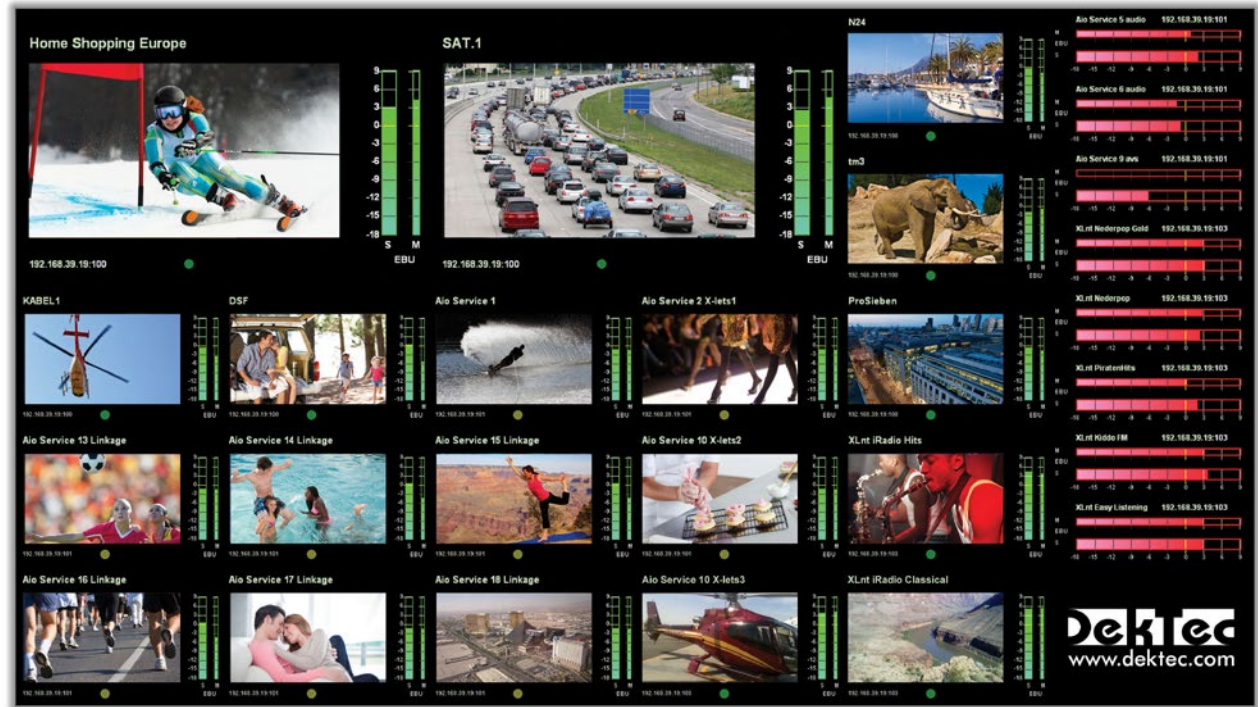

Monitored Stream Types

Type	Standard
Audio	MPEG-1
	MPEG-2
	AC3
	(HE-)AAC
Video	MPEG-2
	AVC/H264
DVB subtitles	EN 300 743
Teletext subtitles	ETS 300 706
Closed Captioning	EIA/CEA-608-B
Status	TR 101 290
	Template status

Key Attributes

Parameter	Value
Performance indication	60x SD MPEG-2, or example for 64-bit Win 7 Intel Core i7 3770*
Platform	64-bit Windows 2k8, 2k12, 2k16, 2k19, 10, 11
Processor	High-end Core i7

* Actual figures could be lower or higher depended on complete PC and Xpect® configuration

Ordering Information

Type	Description
DTC-720-nPT	Mosaic functionality is part of the DTC-720 Xpect® product; No extra license points are required

DTAPI

Uniform API for DekTec Digital Video Adapters

Features

- Common C++/.NET interface to DekTec's line of digital-video interface adapters
- Includes **DekTec Matrix API**® for manipulating 3G/HD-SDI and **Advanced Demodulator API** for RF measurements and multiple stream demodulation
- Applications written for one device will work for any other DekTec device
- Encapsulates the device-driver layer in an easy-to-use object-oriented interface
- Access to all hardware features from user-mode programs
- High efficiency; no need to resort to kernel-mode programming to achieve real-time operation
- Same API classes and methods can be used for PCI, PCI Express, USB-2 and networked devices
- Same API classes and methods can be used on Windows and Linux
- Packaged in a C++ header file (to be included in your C++ project) and a library (to be linked to the application)
- Free download
- Royalty-free redistribution in custom applications

Applications

- Creating custom applications with DekTec devices in a convenient way

Note

DTAPI cannot descramble services

Software Development Kits

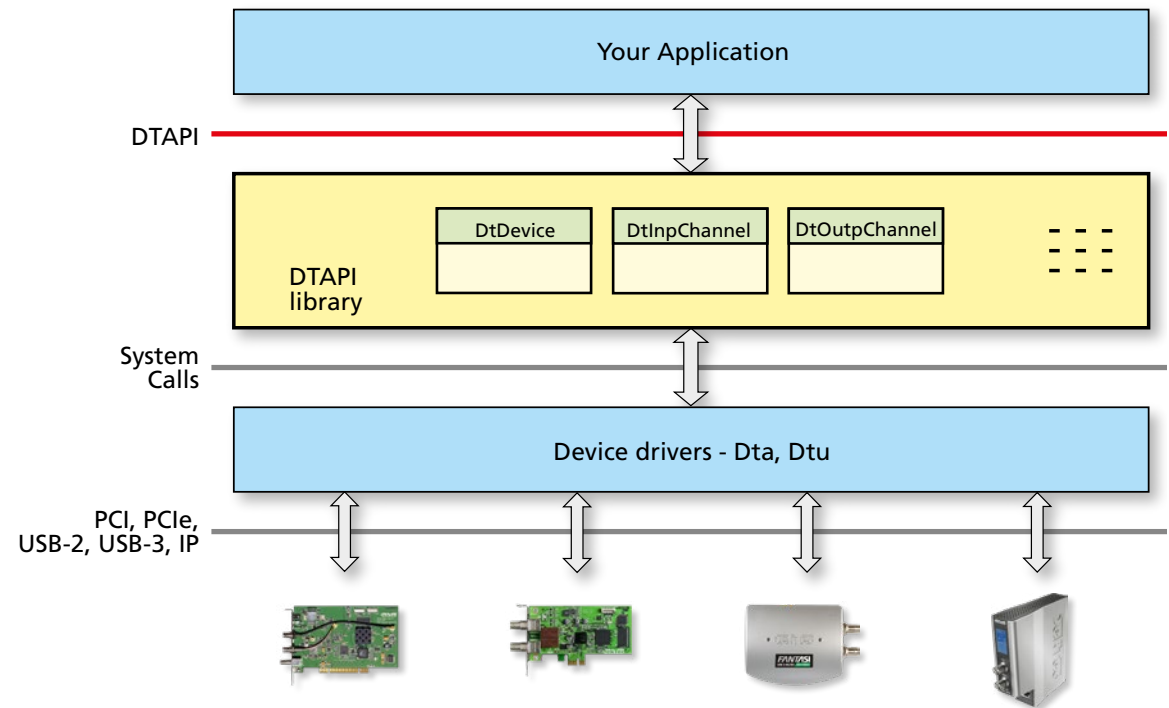

Supported DekTec Devices

Signal Type	Supported Adapters
DVB-ASI	DTA-2160 DTE-3100, 3120
ASI/SDI	DTA-2142, 2144B, 2145, 2152, 2172, 2174(B), 2175, 2178, 2179, 2195 DTU-350, 351
Modulators	DTA-2107, 2111, 2115B DTU-215, 315
Receivers	DTA-2127, 2131, 2132, 2135, 2136, 2137C, 2138B, 2139B/C DTU-234, 235, 236A, 331
TS/SDI-over-IP	DTA-2110, 2160, 2162
H.264 encoder	DTA-2180, 2182

PC Requirements

Platform	Windows 10, 11 Windows Server 16, 19, 22 Linux ≥2.6.18, 3.x, 4.x, 5x
Processor	Any x86 processor

Main Classes In DTAPI

Class	Represents
DtDevice	DekTec device
DtInpChannel	Input channel
DtOutpChannel	Output channel
DtSdi	SDI helpers
DtFrameBuffer	3G/HD/SD-SDI frame buffer
DtSdiMatrix	Matrix of SDI frame buffers

DTAPI-TS

Transport-Stream Analysis and Monitoring SDK

Features

- C++ library for adding transport-stream analysis functions to your application
- Get list of services, service info (e.g. name) and elementary stream info (e.g. audio sample rate or video resolution)
- Bitrate measurement (average/min/max) with programmable sliding window
- PCR analysis with PCR-AC and PCR-OJ
- Full decoding of PSI, DVB-SI and ATSC PSIP tables and descriptors
- User-supplied callback functions can be fired upon certain events, e.g. when table data has changed, when a new PES packet was received, etc.
- Easy to use: (1) supply packets with the NewData() function, and (2) read analysis results from class DtTsData
- Transport-stream data can be supplied from any source: DekTec input card, file, network data, 3rd party hardware
- Single developer and site license available
- Applications developed with DTAPI-TS can be used or distributed royalty free

Applications

Apply transport stream analysis and monitoring to the transport stream input(s) of your application, without writing any parsing code:

- Discover services and streams
- Create TS information display
- Detect transport stream errors
- Get contents of SI tables and/or descriptors

Software Development Kits

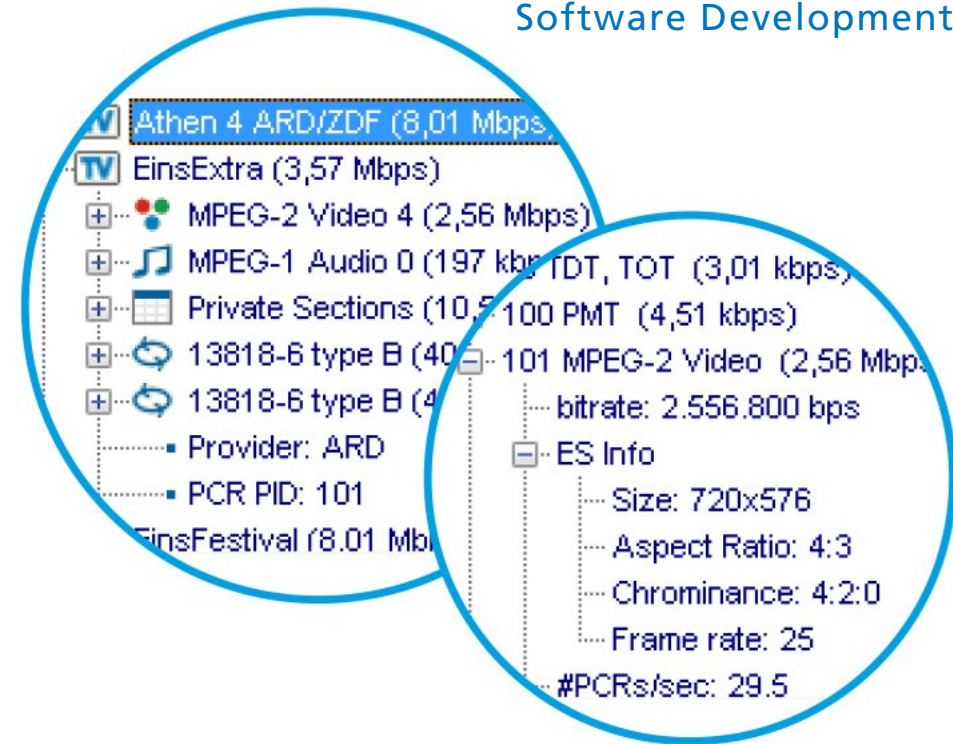

Service information extraction (DVB/ATSC)
PCR analysis and bitrate measurement
Modest NRE fee; Royalty-free distribution

General Info

Platform	Windows, Linux
Language	C++
Threading	Locking mechanism for usage in multi-threaded applications
Compiler	Visual Studio 2015 or later GCC 4.8 or later
Processor	Any x86 processor

Ordering Information

Type	Description
DTC-730-1DEV	DTAPI-TS, Transport Stream analysis SDK, single developer
DTC-7301-YR	1yr software maintenance for DTC 730-1DEV
DTC-732-SITE	DTAPI-TS, site license
DTC-7321-YR	1yr software maintenance for DTC 732-SITE

MuxXpert SDK

SDK for Creating Custom Multiplexing Applications

Features

- The MuxXpert SDK is a development kit for the embedding of real-time multiplexing functions in your custom application
- The classes can be used to create custom:
 - Service and component selection
 - SI processing
 - Remote control
 - User interface
- Provides all functions of the MuxXpert: re-multiplexing of services and components, querying the structure of transport streams, SI extraction, table cycling, adaptation of PIDs, services, tables and descriptors
- Runs on a standard- or industrial PC with all DekTec input and output adapters
- Can be used from any .NET language such as C++/CLI, C# or VB.NET
- Location transparency: The real-time multiplexing functions running on one PC can be used from anywhere on the network
- MuxXpert SDK consists of one DTC-700-MX MuxXpert license, one DTC-705-MR run-time license, manual and help file, merge module and four hours of premium support

Applications

- Re-multiplexer with custom SI processing
- Electronic Program Guide inserter
- Generation of MuxXpert configuration files

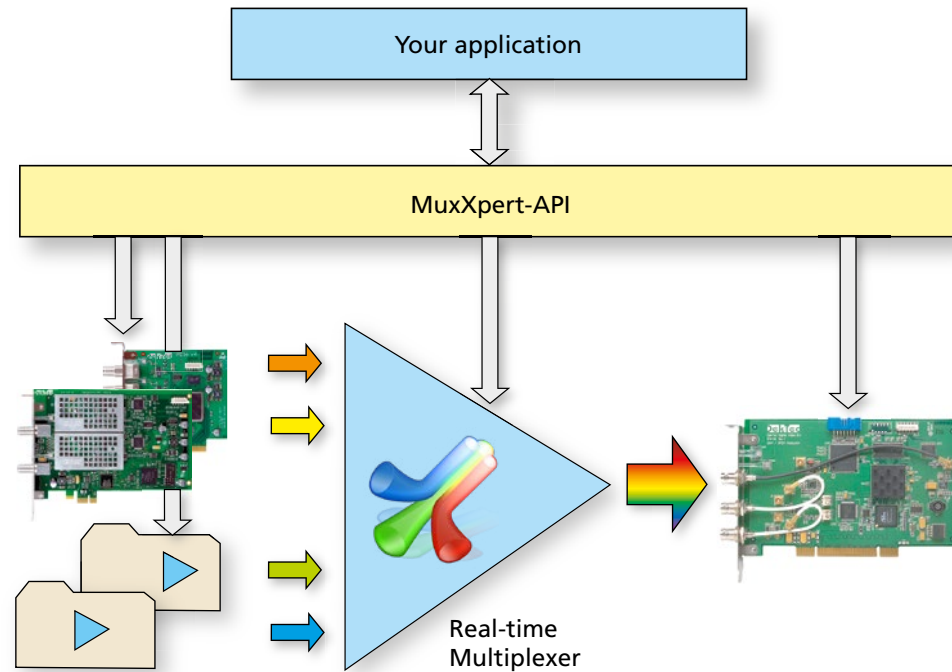

Key Attributes

Parameter	Value
Number of TS inputs	0 to 64*
Number of TS outputs	1 to 64*
Number of file players	0 to 32*
Sum of input rates	0 to 300Mbit/s
Sum of output rates	0 to 300Mbit/s

* Not all combinations are allowed and depend on CPU speed and RAM.

PC Requirements

Platform	Windows 10, 11 1GB to 4GB
Processor*	Core i5, i7

* Or equivalent AMD processor

Supported I/O Adapters

Bus	Types
PCI Express	DTA-2107, 2110, 2111, 2115B, 2127, 2131, 2132, 2136, 2137C, 2138B, 2139B/C, 2144B, 2145, 2152, 2160, 2162, 2172, 2174(B), 2175, 2178, 2179, 2180, 2182, 2195
USB	DTU-215, 315, 331, 245*
IP	DTE-3100, 3120, Local NIC

* For evaluation and demos, not recommended for operational use.

Ordering Information

Type	Description
DTC-705-MR	MuxXpert runtime license (1PC)
DTC-706-MS	MuxXpert SDK

Distributors

DekTec products are shipped worldwide. Please direct any commercial enquiries or formal quotation requests to the appointed distributor in your country. A list of officially appointed distributors is provided in the contact section of our website. If no distributor is listed for your country, you can email directly to info@dektec.com.

Open Pricing

DekTec operates an open pricing policy. You can find the latest prices of each product on our website. Distributors shall not charge a price that exceeds the DekTec published price, but please beware that local prices may slightly exceed the

published prices to account for customs duties and currency exchange-rate fluctuations.

Credit Card Payment and Shipment

For urgent product requirements, DekTec accepts payment by credit card (VISA and MasterCard). Shipment is worldwide by FedEx International Priority shipment, or by your preferred courier.

DekTec - The OEM Supplier

DekTec is a leading supplier of OEM components for integration in your solution. DTAPI, DekTec's critically acclaimed SDK, provides comprehensive support that reinforces the OEM-friendly nature of our products. We provide the SDK free of charge without NDA or complex registration requirement.

Extensive Range

Most of DekTec's product range in this catalogue is suitable for OEM, including the USB products that can be supplied as an assembled PCB board only. By keeping the products standard we can keep the cost of the OEM low, along with immediate stock availability.

DekTec's OEM Minimum Order Quantity = 1

For integrators and OEM's requiring small quantities, e.g. for development of your solution or for a test run, DekTec units are available in single quantity immediately from stock.

Custom Branding

We will consider custom branding to meet specific OEM client requirements, subject to a minimum order quantity.

Warranty

DekTec's hardware is supported with a no-quibble two-year worldwide warranty. This period can be optionally extended up to seven years to provide added assurance in your critical applications.

DekTec Software

DekTec software is supplied on a USB flash drive* and via the Downloads section on our website. We provide a utility program DtInfo to help checking proper installation, licensing information, serial numbers and driver version numbers. DtInfo can also be used to install newly purchased licenses. Software upgrades are available freely for a period of one year after purchasing.

* supplied when hardware and software is purchased together.

Pleasure in the job puts perfection in the work.

Aristotle



DekTec Digital Video B.V. - Godelindeweg 4, 1217 HR Hilversum - The Netherlands
info@dektec.com - Tel: +31 35 2030100 - Fax: +31 35 2030101 - twitter.com/DekTec - www.dektec.com



[Back to content](#)