

DTE-3114

| Networked Quad QAM Modulator



USER MANUAL

March 2017

DekTec

Table of Contents

| | |
|--|----|
| 1. Introduction..... | 4 |
| 1.1 General description | 4 |
| 1.2 Block diagram..... | 4 |
| 1.3 Applications | 5 |
| 1.4 Limitations | 5 |
| 1.5 List of Abbreviations..... | 6 |
| 2. Installation | 8 |
| 2.1 Physical layout..... | 8 |
| 2.2 LCD display | 9 |
| 2.3 Hardware installation | 10 |
| 2.4 Thermal considerations | 11 |
| 2.5 IP address assignment..... | 11 |
| 2.6 Failsafe mode..... | 14 |
| 2.7 Factory defaults | 14 |
| 2.7.1 SMPTE Settings | 14 |
| 2.7.2 Modulator Settings..... | 14 |
| 2.7.3 Network Settings..... | 15 |
| 2.7.4 Alarm Settings..... | 15 |
| 3. Device Configuration and Monitoring..... | 16 |
| 3.1 Control interfaces | 16 |
| 3.2 Manageable items | 16 |
| 3.2.1 Device | 16 |
| 3.2.2 Network Settings..... | 17 |
| 3.2.3 SMPTE Settings | 18 |
| 3.2.4 Modulator Settings..... | 18 |
| 3.2.5 Status | 19 |
| 3.2.6 SNMP alarms | 20 |
| 3.3 Web GUI | 20 |
| 3.3.1 Web GUI – Information box..... | 20 |
| 3.3.2 Web GUI – Colour-coding scheme | 21 |
| 3.3.3 Web GUI – Tabs..... | 21 |
| 3.3.4 Web GUI – Error handling..... | 22 |
| 3.4 SNMP..... | 22 |
| 3.4.1 SNMP – MIBs..... | 22 |
| 3.4.2 SNMP – Actual and desired settings | 23 |
| 3.4.3 SNMP – Traps | 23 |
| 3.5 Settings errors | 23 |
| 3.6 Firmware upgrade | 25 |
| 4. System Configuration | 26 |
| 4.1 General..... | 26 |
| 4.2 Managing bitrates..... | 26 |

| | |
|--|----|
| 4.3 IP jitter | 28 |
| 5. Specifications..... | 30 |
| 5.1 Network connection | 30 |
| 5.2 Transport-Stream input over IP | 30 |
| 5.3 RF Outputs..... | 31 |
| 5.4 Modulation | 32 |
| 5.5 Other Specifications | 32 |
| Appendix A. DTE-MIB..... | 34 |
| Appendix B. DTE-QAM-MIB | 47 |



Copyright © 2009-2017 by DekTec Digital Video B.V.

DekTec Digital Video B.V. reserves the right to change products or specifications without notice. Information furnished in this document is believed to be accurate and reliable, but DekTec assumes no responsibility for any errors that may appear in this material.

1. Introduction

1.1 General description

The DTE-3114 is a compact four-channel QAM modulator with Transport Stream over IP (TSolP) inputs and a directly synthesized VHF/UHF output. The device can operate in DVB-C, J.83 Annex B and J.83 Annex C mode, with support for the various QAM constellations and interleaver modes.

The unit accepts unicast and multicast streams over its Gigabit-Ethernet port, and modulates the four TSolP streams to four adjacent channels anywhere between 32 and 1006MHz. Key features include de-encapsulation of UDP or RTP, accurate timing reconstruction using innovative algorithms to overcome IP jitter, as well as error correction according to SMPTE 2022-1.

A significant innovation in the DTE-3114 is support for Power over Ethernet (PoE). When used with a PoE compatible network, the modulator does not require a separate power feed, as it can draw its power from the Ethernet network. A power jack is still offered where PoE is not available.

The DTE-3114 supports SNMP management and has an easy-to-use web-based user interface for configuration purposes, as well as retrieving status information and performance statistics. The LCD status display shows the user-programmable device identifier, current configuration information and IP/MAC address.

1.2 Block diagram

Figure 1 shows the functional block diagram of the DTE-3114. Each of the four channels starts with an IP filter that selects IP packets for the configured unicast or multicast address. The resulting IP packets are converted to a Transport Stream, which will typically be a Multi-Program Transport Stream (MPTS). In this block any lost packets are recovered in the FEC decoder and the input TS rate is accurately estimated. Buffering with a configurable delay is included to be able to tolerate IP jitter.

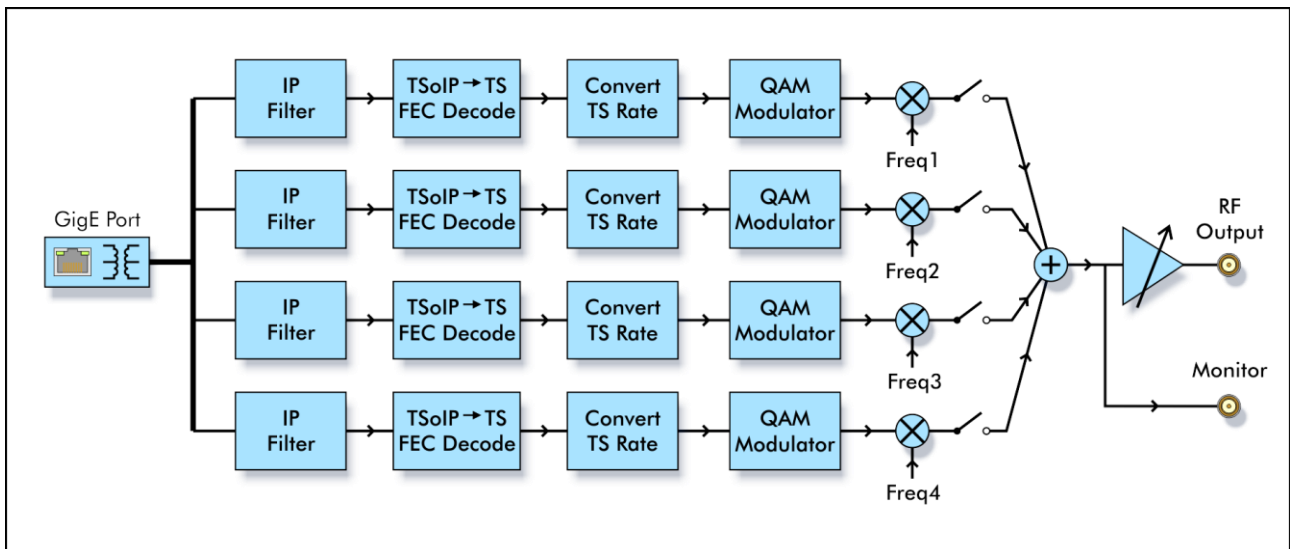

Figure 1. Functional block diagram of the DTE-3114.

After reconstructing the Transport Stream its rate is converted to the rate corresponding to the modulation settings (QAM constellation, symbol rate). Rate conversion comprises inserting null packets and adjusting the PCR time stamps. Then the packets are QAM modulated according to the

selected QAM standard and mode. Channel filtering is applied and the resulting QAM-modulated signal is digitally upconverted to an RF carrier in the VHF or UHF band.

The outputs of the four channels are added to each other, optionally with a plus or minus 3dB RF-level correction per channel. The result is converted to analog, amplified with an adjustable gain and put on the RF output. A second output with a fixed level is provided for monitoring purposes.

An embedded μ P system (not shown in the functional block diagram) hosts a web and SNMP agent to interface with the user or an SNMP network-management system. The control parameters are stored in non-volatile memory and retrieved automatically after a power cycle.

1.3 Applications

Typical applications of the DTE-3114 include:

QAM test-signal generator

The DTE-3114 can be used as a standard QAM test-signal generator by using a PC to send a test Transport Stream over IP to the DTE-3114. Typical uses include generating QAM signals in an R&D environment, demonstration of QAM receiving equipment on exhibitions and production testing of QAM-processing equipment.

Cable network simulator

The development of silicon tuners and line amplifiers requires simulation of fully loaded spectrum conditions. Testing and debugging of Electronic Program Guide (EPG) and other software for QAM set-top boxes or TV sets can benefit greatly from a multi-channel test signal that is under control of the developer.

Such a simulation of a real cable network can be created by combining the output of multiple DTE-3114s. For example, 64 channels can be created using 16 devices. It is not required to generate a TSolP stream for every RF carrier: Multiple channels can be configured to join the same multicast group.

Small-scale CATV

A natural application for the DTE-3114 is as a high-density, low-cost QAM modulator in small-scale cable television applications, for example in hospitals, student campuses or holiday parks. The MPTS TSolP streams can be generated by DekTec's MuxXpert product running on standard PC servers.

1.4 Limitations

The structure of the hardware brings with it a number of limitations. The main limitations are listed below.

| | |
|---------------------|---|
| Channel frequency | Channels must be grouped: the overall output spectrum of the DTE-3114 cannot be wider than 32Mhz. |
| Modulation standard | All channels operate in the same mode, e.g. DVB-C, 256-QAM. |
| Symbol rate | Range 4.48 - 7MBd. Each channel uses the same symbol rate. |
| RF level | The RF level of the 4 channels must be positioned in a band of plus or minus 3dB. |

| | |
|--------------------|---|
| Conditional access | Not supported. |
| Multiplexing | SPTS to MPTS multiplexing is not supported. |
| VBR | Only CBR streams are supported. |

1.5 List of Abbreviations

| | |
|-----------|---|
| auto-MDIX | Automatic medium-dependent interface crossover. Technique to automatically detect the type of network cable: straight-through or crossover. |
| CATV | Cable Television |
| CBR | Constant Bit Rate |
| DHCP | Dynamic Host Configuration Protocol. Network protocol to automatically assign an IP address to a network port from a server. |
| DVB | Digital Video Broadcasting |
| DVB-C | DVB standard for modulation appropriate for in cable networks |
| EPG | Electronic Program Guide |
| FEC | Forward Error Correction |
| IP | Internet Protocol |
| LCD | Liquid Crystal Display |
| MAC | Media Access Controller |
| MBd | Megabaud. Number of symbols per second. |
| Mbps | Megabit per second |
| MIB | Management Information Base. The set of status and control variables accessible through the SNMP protocol. |
| MPTS | Multi-Program Transport Stream |
| NA | Not Applicable |
| NMS | Network Management System |
| PCR | Program Clock Reference |
| PoE | Power over Ethernet |
| ppm | Parts per million |
| QAM | Quadrature Amplitude Modulation |
| RF | Radio Frequency |
| RO | Read Only |
| R/W | Read / Write |
| SMPTE | Society of Motion Picture and Television Engineers |
| SNMP | Simple Network Management Protocol |

| | |
|-------|--|
| RTP | Real-time Transport Protocol |
| TSoIP | Transport Stream over IP |
| UDP | Unreliable Datagram Protocol |
| UHF | Ultra High Frequency band, officially ranging from 300MHz to 3GHz, but in the context of cable television from 300MHz to 1GHz. |
| URL | Uniform Resource Locator |
| VBR | Variable Bit Rate |
| VHF | Very High Frequency band, ranging from 30 to 300MHz |
| WO | Write Only |

2. Installation

2.1 Physical layout

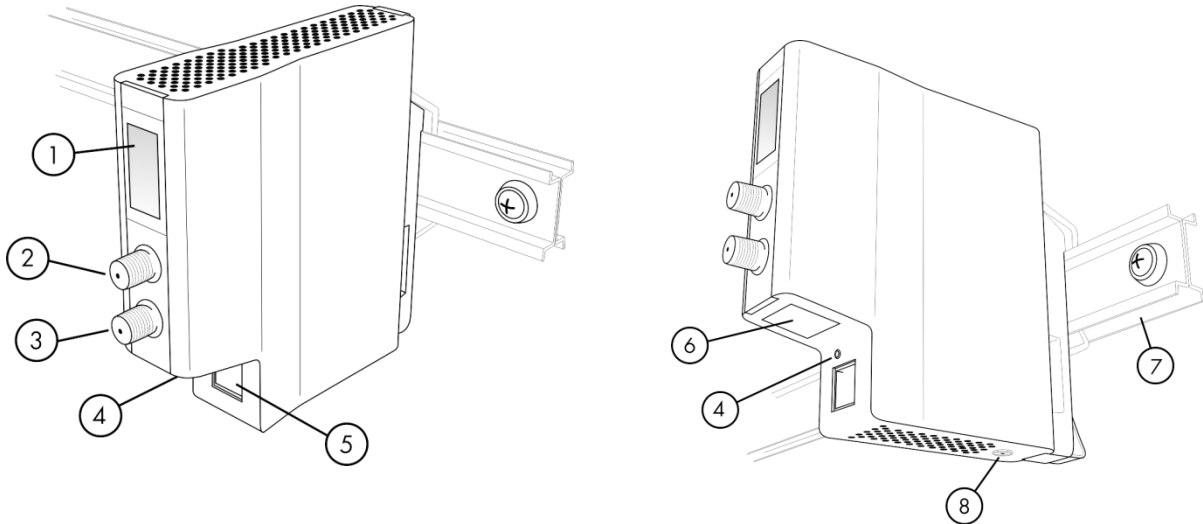

- | | | |
|----|--------------------|--|
| 1. | LCD display | The LCD display indicates the device identifier and device status information. |
| 2. | Main RF output | F female connector, 75 Ohm impedance. |
| 3. | Monitor RF output | F female connector, 75 Ohm impedance. |
| 4. | Reset button | Button that can be operated with a paper clip. The function is to reboot the DTE-3114, or enter failsafe mode if held pressed for more than three seconds. |
| 5. | RJ-45 Gigabit port | The Ethernet port is used to supply TS-over-IP input, Web and SNMP management and (optionally) power supply from a Power-over-Ethernet enabled network. |
| 6. | Label | Label containing the device's serial number and MAC address. |
| 7. | Rail-mount system | The Rail-mount system is used to install the DTE-3114 on the DekTec 19"-rack-mountable rail or a DIN Rail. |
| 8. | 24V DC power jack | An auxiliary power supply (24V/400mA) can be used when Power-over-Ethernet is not available. |

2.2 LCD display

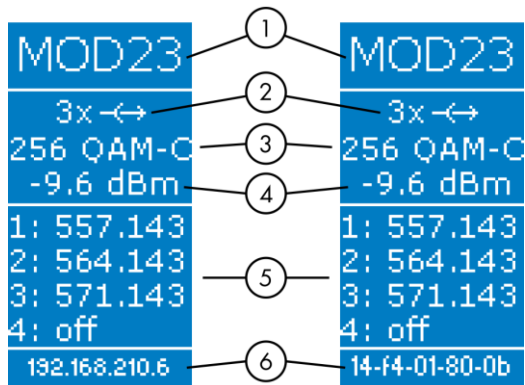

The LCD display contains the following information:

- | | | |
|----|-------------------|--|
| 1. | Device identifier | Programmable from the web and SNMP interface. |
| 2. | Active channels | Number of channels that have been enabled. If no channels are active, "Idle" is displayed. |
| 3. | Mode | QAM mode and modulation standard. |
| 4. | RF level | Total output power level in dBm. |
| 5. | Frequency | Carrier frequency of each channel in MHz. |
| 6. | Network address | MAC address and IP address (alternating). |

When a hardware failure is detected the display will blink continuously and the DTE-3114 has to be returned to the manufacturer.

2.3 Hardware installation

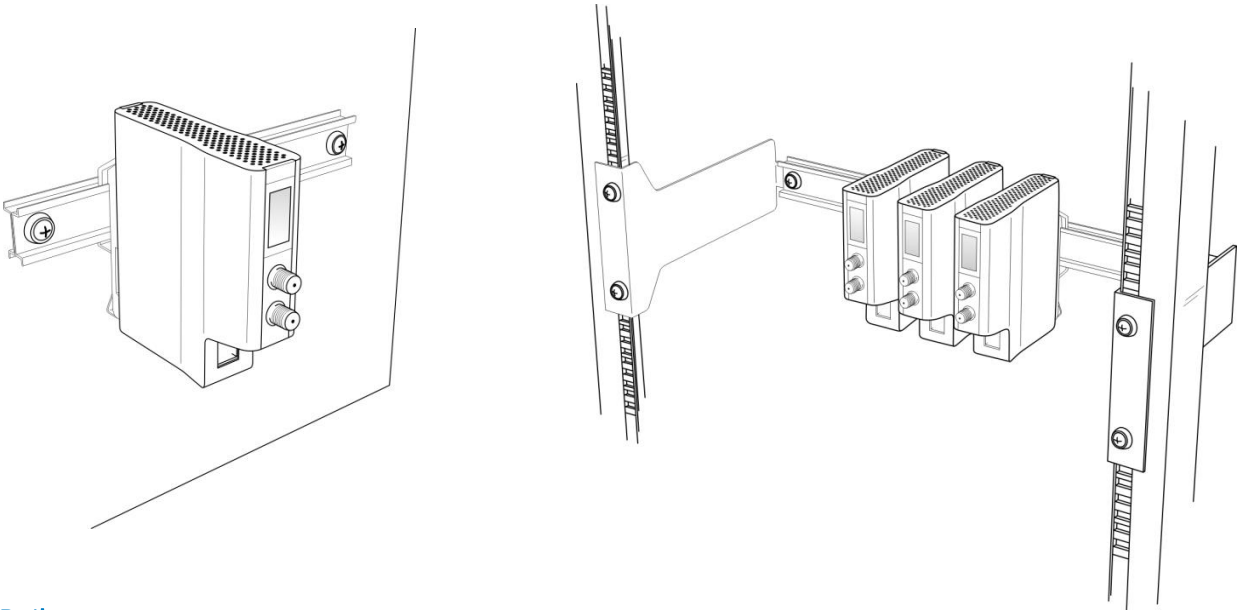

Rail-mount system

The rail-mount system can be used to mount the DTE-3114 on a DIN rail (TS32, TS35). The rail can be mounted directly on a wall, or the DekTec 19"-rack-mountable rail can be used to install up to 12 DTE modules in 3U-height 19" rack space. Special consideration is required to avoid overheating of the unit, see section 2.4.

Network connection

A standard Cat5 (or higher) patch cable can be used to connect a DTE-3114 to the network. Either a straight-through or cross-over network cable can be used; the type of cable will be automatically recognized (auto-MDIX operation). The DTE-3114 will automatically select the link speed of the connected network (10/100/1000Mbps).

Power

The DTE-3114 can be powered from the network using Power over Ethernet (PoE). Alternatively, when the switch supports Ethernet without PoE, a 24V/400mA power adapter can be applied using the auxiliary 24V DC power jack. If both PoE and auxiliary power are supplied, the DTE-3114 will use auxiliary power.

Note: Switching between the power supplies (e.g. connecting auxiliary power while the unit is operational in PoE mode) can cause a restart of the DTE-3114.

RF outputs

The DTE-3114 has a 75-Ω main RF output and a 75-Ω RF monitoring output. The RF level of the main output can be configured by the user to a power level between -32 and -9dBm; The RF level of the monitor output (-25.5dBm) is not adjustable.

Reset button

When the DTE-3114 is operational and the reset button is hold down for approximately one second the device will reboot and the device will obtain an IP address through DHCP (even if a static IP address was configured). This should be required in exceptional cases only, because the DTE-3114 has an internal watchdog function that automatically resets the device if the software crashes.

If the reset button is held down for more than three seconds, the DTE-3114 will enter failsafe mode, see section 2.6.

2.4 Thermal considerations

The DTE-3114 is designed to operate with cooling by natural convection, without active cooling facilities. However, the following considerations have to be taken into account:

- The unit must always be mounted vertically to allow bottom-to-top airflow.
- The units must be installed in such a way that airflow is not obstructed. In no case the vent holes should be covered when the DTE-3114 is enabled.
- If multiple units are mounted next to each other on a rail, the units should be spaced at least 0.5cm apart.
- The ambient temperature should be lower than 35°C / 95°F. If this condition cannot be met, forced air cooling should be applied with a vertical-flow fan unit mounted below the units.

A thermal shutdown mechanism is in place to avoid overheating of the unit. If the internal temperature of the DTE-3114 rises above 85°C / 185°F, the RF output of the device will be disabled.

2.5 IP address assignment

Within a network each connected device needs to have a unique IP address to enable reliable communication between the devices. If multiple devices would have the same IP address, conflicts may occur and communication becomes unreliable. The IP addresses in a network can be configured by the user with fixed unicast IP addresses or via a DHCP server on the network.

Upon applying power, the DTE-3114 will try to connect to a DHCP server to obtain an IP address, unless a static IP address has been configured. In the latter case, the DTE-3114 will start with the configured static IP address.

If no static IP address has been configured and no DHCP server is running (or if the DHCP server cannot be reached) the DTE-3114 will automatically assign itself an address in the range from 169.254.1.0 to 169.254.254.255 (Link-local address, RFC 3927) with subnet 255.255.0.0.

The selected IP address is shown at the bottom of the illuminated LCD display on the DTE-3114. The IP address is interchanged with the MAC address every few seconds.

Note: The MAC address can also be found on the label attached to the DTE-3114, above the network connector.

A web browser on the same subnet can now be used to connect to the unit, by using the IP address as URL, e.g. <http://192.168.1.10/>. For easy access to a specific DTE-3114, the IP address can be added to the list of browser favorites and given a name.

When you have access to the web pages of the DTE-3114 web interface, you can – if you want to do so – assign a static IP address and subnet mask via the Network settings tab. The default gateway can be specified, too, but this is not required.

How to reach a DTE-3114 with IP address 169.254.x.x?

This problem may occur in a network with statically assigned IP addresses, without DHCP server. The DTE-3114 has assigned itself a link-local address 169.254.x.x. However, the browser PC has a static IP address that will most likely reside on a different subnet.

A web browser running under Windows Vista, Windows 7 or Linux will still be able to access the DTE-3114, because these operating systems recognize link-local addresses as a special case. However, a web browser running on Windows XP will not be able to gain access to the device, because the subnet of the web browser is different from the DTE's subnet.

To access the DTE-3114 from Windows XP it is required that the link-local subnet is present in the routing table. This can be verified by using the command: *route print*. In the routing table only one link-local route (169.254.x.x) may be present through the network card which is connected to the DTE-3114.

Example 1:

Assume that a PC running XP hosts 2 network cards with fixed IP addresses 192.168.100.28 and 192.168.200.3 and no DHCP server is available. The DTE-3114 is located on the network segment connected to the network card with IP address 192.168.200.3 and has assigned itself link-local IP address 169.254.225.123. The "route print" command may give the following result:

```
C:\>route print
=====
Interface List
0x1 ..... MS TCP Loopback interface
0x2 ...00 14 f4 00 00 2b ..... DekTec DTA-160 Gigabit Ethernet Port
0x3 ...00 1c c0 38 60 33 ..... Intel(R) 82566DC-2 Gigabit Network Connection
=====
Active Routes:
Network Destination        Netmask          Gateway          Interface        Metric
0.0.0.0                    0.0.0.0          192.168.100.100  192.168.100.28   20
127.0.0.0                  255.0.0.0        127.0.0.1       127.0.0.1        1
192.168.100.0              255.255.255.0    192.168.100.28  192.168.100.28   20
192.168.100.28             255.255.255.255  127.0.0.1       127.0.0.1        20
192.168.100.255           255.255.255.255  192.168.100.28  192.168.100.28   20
192.168.200.0              255.255.255.0    192.168.200.3   192.168.200.3    10
192.168.200.3             255.255.255.255  127.0.0.1       127.0.0.1        10
192.168.200.255           255.255.255.255  192.168.200.3   192.168.200.3    10
224.0.0.0                  240.0.0.0        192.168.100.28  192.168.100.28   20
224.0.0.0                  240.0.0.0        192.168.200.3   192.168.200.3    10
255.255.255.255           255.255.255.255  192.168.100.28  192.168.100.28   1
255.255.255.255           255.255.255.255  192.168.200.3   192.168.200.3    1
Default Gateway:          192.168.100.100
=====
Persistent Routes:
None
```

In this routing table no link-local route is present. To add the route use the following command:

```
route ADD 169.254.0.0 MASK 255.255.0.0 192.168.200.3
```

This will result in the following routing table:

```
C:\>route print
=====
Interface List
0x1 ..... MS TCP Loopback interface
0x2 ...00 14 f4 00 00 2b ..... DekTec DTA-160 Gigabit Ethernet Port
0x3 ...00 1c c0 38 60 33 ..... Intel(R) 82566DC-2 Gigabit Network Connection
=====

Active Routes:
Network Destination        Netmask          Gateway          Interface        Metric
    0.0.0.0                0.0.0.0         192.168.100.100  192.168.100.28   20
    127.0.0.0              255.0.0.0         127.0.0.1       127.0.0.1        1
    169.254.0.0            255.255.0.0         192.168.200.3   192.168.200.3    1
    192.168.100.0          255.255.255.0     192.168.100.28  192.168.100.28   20
    192.168.100.28         255.255.255.255     127.0.0.1       127.0.0.1        20
    192.168.100.255        255.255.255.255     192.168.100.28  192.168.100.28   20
    192.168.200.0          255.255.255.0     192.168.200.3   192.168.200.3    10
    192.168.200.3          255.255.255.255     127.0.0.1       127.0.0.1        10
    192.168.200.255        255.255.255.255     192.168.200.3   192.168.200.3    10
    224.0.0.0              240.0.0.0         192.168.100.28  192.168.100.28   20
    224.0.0.0              240.0.0.0         192.168.200.3   192.168.200.3    10
    255.255.255.255        255.255.255.255     192.168.100.28  192.168.100.28   1
    255.255.255.255        255.255.255.255     192.168.200.3   192.168.200.3    1
Default Gateway: 192.168.100.100
=====

Persistent Routes:
None
```

The link-local route is now present and communication with the DTE-3114 is possible.

Example 2:

Same situation as example 1, but now the "route print" gives the following result:

```
C:\>route print
=====
Interface List
0x1 ..... MS TCP Loopback interface
0x2 ...00 14 f4 00 00 2b ..... DekTec DTA-160 Gigabit Ethernet Port
0x3 ...00 1c c0 38 60 33 ..... Intel(R) 82566DC-2 Gigabit Network Connection
=====

Active Routes:
Network Destination        Netmask          Gateway          Interface        Metric
    0.0.0.0                0.0.0.0         192.168.100.100  192.168.100.28   20
    127.0.0.0              255.0.0.0         127.0.0.1       127.0.0.1        1
    169.254.0.0            255.255.0.0         192.168.100.28  192.168.100.28   1
    169.254.0.0            255.255.0.0         192.168.200.3   192.168.200.3    1
    192.168.100.0          255.255.255.0     192.168.100.28  192.168.100.28   20
    192.168.100.28         255.255.255.255     127.0.0.1       127.0.0.1        20
    192.168.100.255        255.255.255.255     192.168.100.28  192.168.100.28   20
    192.168.200.0          255.255.255.0     192.168.200.3   192.168.200.3    10
    192.168.200.3          255.255.255.255     127.0.0.1       127.0.0.1        10
    192.168.200.255        255.255.255.255     192.168.200.3   192.168.200.3    10
    224.0.0.0              240.0.0.0         192.168.100.28  192.168.100.28   20
    224.0.0.0              240.0.0.0         192.168.200.3   192.168.200.3    10
    255.255.255.255        255.255.255.255     192.168.100.28  192.168.100.28   1
    255.255.255.255        255.255.255.255     192.168.200.3   192.168.200.3    1
Default Gateway: 192.168.100.100
=====

Persistent Routes:
None
```

In this routing table two link-local routes are present: one from network interface 192.168.100.28 and one from 192.168.200.3. Dual routes can result in incorrect communication with the

DTE-3114, so one of them should be deleted. To remove the link-local route through 192.168.100.28, use the following command:

```
route DELETE 169.254.0.0 MASK 255.255.0.0 192.168.100.28
```

This will result in a correct routing table.

2.6 Failsafe mode

The DTE-3114 supports a special “failsafe” mode to enable recovery from an erroneous configuration. In failsafe mode the unit has no modulation functionality and the user can only configure the IP address and load new firmware.

Failsafe mode is entered in the following cases:

- A firmware upgrade of the DTE-3114 has failed.
- The reset button is kept pressed while the DTE-3114 powers up.
- The reset button is kept pressed for at least 3 seconds.

In the latter two cases, the DTE-3114 will obtain an IP address through DHCP, even if a static IP address was configured.

In failsafe mode just 3 tabs are enabled in the web interface:

- *Network Settings*. This allows for changing the IP-address settings.
- *Application Switcher*. The operational application can be selected. In the current version of the DTE-3114 just one application is present, so there is nothing to chose.
- *Firmware Upgrade*. See section 3.5 for more information.

2.7 Factory defaults

2.7.1 SMPTE Settings

| | |
|-----------------|---|
| Addressing mode | multicast |
| IP addresses | 224.1.1.1, 224.1.1.2, 224.1.1.3, 224.1.1.4 |
| Ports | 8000, 8010, 8020, 8030 |
| FEC decoding | enabled |
| IP-to-RF delay | 100ms |

2.7.2 Modulator Settings

| | |
|--------------------|-----------------------|
| Channel enable | disabled |
| Frequency | 600, 608, 616, 624Mhz |
| Modulation | DVB-C |
| QAM mode | 256-QAM |
| Spectral inversion | disabled |
| Interleaver mode | I=128, J=1 |
| RF level | -20dBm |

2.7.3 Network Settings

| | |
|-----------------------|---------------------|
| IP address | obtain through DHCP |
| Display ID | <blank> |
| SNMP agent | disabled |
| SNMP read community | public |
| SNMP write community | private |
| SNMP traps | disabled |
| SNMP trap destination | 0.0.0.0 |
| SNMP trap community | public |
| SNMP trap Port | 162 |

2.7.4 Alarm Settings

| | |
|-----------------------------|----------|
| Temperature alarm | disabled |
| Temperature alarm threshold | 65°C |
| RF alarm value | 2dB |
| RF alarm | disabled |

3. Device Configuration and Monitoring

3.1 Control interfaces

The DTE-3114 can be configured and monitored in two ways:

- Through a web-based front end (“web GUI”), see section 3.3;
- Using SNMP, see section 3.4

The web GUI is intended for human interaction with the DTE-3114, while SNMP is aimed at automated management and control by a Network Management System.

The two control interfaces, web and SNMP, can be used in parallel to each other. In addition each interface can be used multiple times in parallel, e.g. two web browser sessions may connect to the same DTE-3114.

3.2 Manageable items

The table below provides a list of variables and concepts that can be configured and/or monitored using the web and/or SNMP interface. Two columns are added, one for the web interface and one for SNMP, to indicate whether the variable is Read Only (RO), Write Only (WO), Read/Write (R/W) or not applicable to this interface (NA).

3.2.1 Device

| Variable | Description | Web | SNMP |
|------------------------|--|-----|------|
| Device type | Device type number: 3114 for DTE-3114 | RO | RO |
| Serial number | Unique serial number for the device. It always starts with 3114, followed by 6 digits | RO | RO |
| Hardware revision | Hardware revision number | RO | RO |
| Firmware version | Firmware version number | RO | RO |
| Power status | Indicates which power source is used. The DTE-3114 can be powered from an external power-supply or via the Ethernet connector (PoE) | RO | RO |
| Temperature | Internal device temperature. When the temperature is above 85°C / 185°F, the web interface will display the temperature in red | RO | RO |
| Display identification | String, maximally 5 characters long, displayed at the top of the LCD display. Can be used as device “name” for identification purposes | R/W | R/W |
| Network link speed | Link speed of the network connection (100/100/1000Mbps) | RO | RO |
| Watchdog counter | Counter that keeps the number of times the processor is restarted because of a watchdog alarm. The watchdog is a piece of electronic circuitry that monitors system activity and generates an alarm when the software in the DTE-3114 crashes or hangs | NA | RO |
| Power cycle counter | Counter that keeps the number of power cycles | NA | RO |

| Variable | Description | Web | SNMP |
|-----------------------------|---|-----|------|
| Device status | Reflects the status of the device: <ul style="list-style-type: none"> • <i>Normal operation.</i> The device is working properly. • <i>Hardware error.</i> A serious and fatal error has occurred in the hardware. The DTE-3114 cannot be used and should be returned to the supplier. • <i>Channel error.</i> One or more of the four QAM-modulator channels is in an error state. See “Channel operational status” in section 3.2.5. • <i>Temperature error.</i> The internal temperature of the DTE-3114 is too high (> 85°C/185°F). The RF output is automatically disabled to reduce heat dissipation. When the temperature drops below 85°C/185°F again, the RF output will be enabled again. | NA | RO |
| Synchronise settings | Writing to this object will synchronize the value of the MIB objects with the current run-time settings, see section 3.4.2 | NA | WO |

3.2.2 Network Settings

| Variable | Description | Web | SNMP |
|------------------------|--|-----|------|
| MAC address | The MAC address of the device | RO | RO |
| DHCP enable | Indicates whether the DTE-3114 shall obtain an IP address through DHCP or whether a fixed IP address shall be used | R/W | NA |
| IP address | IP address to use (fixed IP address mode) | R/W | RO |
| Subnet mask | Identifies which part of the IP address is reserved for the network, and which part is available for host use (fixed IP address mode) | R/W | RO |
| Default gateway | Identifies the IP address of the gateway that is used to route IP packets that are not located on the current subnet (fixed IP address mode) | R/W | NA |
| SNMP agent | | | |
| Enable | Enable or disable SNMP agent | R/W | NA |
| Read community | String that is used as a password to enable reading of parameters via SNMP | R/W | NA |
| Write community | String that is used as a password to enable writing of parameters via SNMP | R/W | NA |

| Variable | Description | Web | SNMP |
|------------------------|--|-----|------|
| SNMP traps | | | |
| Enable | Enable or disable generation of SNMP traps | R/W | R/W |
| Community | The SNMP agent will insert this string in traps to act as an elementary password | R/W | R/W |
| Destination IP address | IP address where SNMP traps are sent to | R/W | R/W |
| Destination IP port | IP port number where SNMP traps are sent to | NA | R/W |

3.2.3 SMPTE Settings

Parameters that control the reception of IP streams. “SMPTE” comes from SMPTE 2022, the standard describing the encapsulation of Transport Packets in IP packets.

| Variable | Description | Web | SNMP |
|---------------------|--|-----|------|
| Channel enable | Enable or disable a channel | R/W | R/W |
| Addressing method | IP addressing method: unicast or multicast reception | R/W | R/W |
| Multicast address | Specifies the IP address of the multicast group to join | R/W | R/W |
| IP port | Specifies the IP port number | R/W | R/W |
| FEC decoding enable | Enable or disable FEC reconstruction. If enabled, the DTE-3114 will attempt to recover lost IP packets. Error recovery is only possible if the transmitter uses the RTP protocol with FEC packets | R/W | R/W |
| IP-to-output delay | The desired delay (in ms) between the reception of an IP packet and the data leaving the channel. More delay will allow the DTE-3114 to cope with more IP jitter. The IP-to-output delay must be high enough in order to enable FEC decoding. See section 4.3. for a detailed description. | R/W | R/W |
| Settings status | Status of the SMPTE settings. The status is either 'ok' or an error indication. Refer to section 3.5 for a list of errors. | RO | RO |

3.2.4 Modulator Settings

In the SNMP, the modulator settings in the MIB should be set for each of the 4 channels, even if the setting must have the same value for all 4 channels.

| Variable | Description | Web | SNMP |
|---------------------|---|-----|------|
| Channel spacing | Difference in MHz between the centre frequencies of two consecutive channels | R/W | NA |
| Frequency | The centre frequency of the channel | R/W | R/W |
| Modulation standard | The modulation standard of the channel (DVB-C / J.83 Annex B / J.83 Annex C) | R/W | R/W |
| QAM mode | The QAM mode of the channel (the number of constellation points) | R/W | R/W |
| Spectral inversion | Enable or disable spectral inversion | R/W | R/W |

| Variable | Description | Web | SNMP |
|-----------------|--|-----|------|
| Symbol rate | The symbol rate of the channel | R/W | R/W |
| Interleaver I | Interleaver parameter I | R/W | R/W |
| Interleaver J | Interleaver parameter J | R/W | R/W |
| RF level | The median desired RF output level per channel. For each of the 4 channels, a small offset can be specified relative to this level | R/W | R/W |
| RF level offset | The desired offset (-3 .. +3dB) relative to "RF level" | R/W | N/A |
| Settings status | Indicates whether the modulator settings are consistent and valid ('ok'), or an error indication. Refer to section 3.5 for a list of errors. | RO | RO |

3.2.5 Status

The status information is available for each of the 4 channels.

| Variable | Description | Web | SNMP |
|-----------------------|--|-----|------|
| Operational status | Operational status of the modulator channel: <ul style="list-style-type: none"> • <i>Ok</i>. The channel is working properly. • <i>Disabled</i>. The channel is disabled. The RF output of the channel is turned off. • <i>Settings error</i>. The (new) settings of the channel are not correct. The settings should be modified before they can be applied. • <i>No input error</i>. The channel is enabled but no valid IP stream is present. | RO | RO |
| Protocol | IP protocol used by the incoming IP stream (UDP / RTP) | RO | RO |
| Number of TP per IP | Number of Transport Packets per IP packet in the incoming IP stream | RO | RO |
| FEC number of rows | Number of FEC rows in the incoming IP stream | RO | RO |
| FEC number of columns | Number of FEC columns in the incoming IP stream | RO | RO |
| Lost before FEC | Number of IP packets lost before FEC reconstruction | RO | RO |
| Lost after FEC | Number of IP packets lost after FEC reconstruction | RO | RO |
| IP jitter tolerance | The time (in ms) that the channel waits to receive 'late' IP packets. This delay enables the channel to tolerate IP jitter up to the indicated value | RO | RO |
| FEC delay | The time (in ms, excluding jitter) required to receive all FEC packets corresponding to a 2D FEC block | NA | RO |
| TS packet size | Size of the MPEG-2 packets in the received Transport Stream | RO | RO |
| TS bitrate | Estimated bitrate of the Transport Stream (188-byte Transport Packets) | RO | RO |
| TS PCR present | Indicates whether the incoming Transport Stream contains PCRs | RO | RO |

| Variable | Description | Web | SNMP |
|--------------------------------|---|-----|------|
| TS rate change counter | Counter that keeps the number of bitrate changes detected | NA | RO |
| IP jitter error counter | Counter that keeps the number of times that the jitter of an IP packet exceeds the IP jitter tolerance for this channel | NA | R |
| Lock error counter | Counter that keeps the number of channel restarts. A channel restart may occur in the following cases: The bitrate of the incoming IP stream changes. The jitter on the incoming IP packets exceeds the IP jitter tolerance for this channel. The bitrate of the incoming IP stream exceeds the maximum input bitrate, resulting in an overflow of the internal buffers. | RO | RO |
| Delay factor | The delay factor in μ s. The delay factor is the maximum difference, observed at the network input of the DTE-3114, between the actual arrival time of a UDP/RTP packet and the ideal (jitterless) arrival time of the packet. The DTE-3114 measures the delay factor once every second. | RO | RO |
| Clear counters | Clears the Lost-before-FEC, Lost-after-FEC and Lock-error counters in the web interface | WO | NA |

3.2.6 SNMP alarms

| Variable | Description | Web | SNMP |
|--------------------------|--|-----|------|
| Temp alarm enable | Enable or disable the temperature alarm | NA | R/W |
| Temp alarm value | Threshold value for the temperature alarm (in degrees Celsius). If the internal device temperature exceeds this value, an alarm is generated | NA | R/W |
| RF alarm enable | Enable or disable the RF alarm | NA | R/W |
| RF alarm value | Maximum difference in dB between the device's target and measured RF level (in tenths of dB) | NA | R/W |

3.3 Web GUI







The web interface can be accessed straightforwardly with a web browser. The following browsers have been tested: Internet Explorer 7 and 8, Firefox 3.5, Safari 4, Chrome 3 and Opera 10. After entering the URL of the device in the address bar of the browser, the Device Status webpage of the DTE-3114 web interface will be displayed by default.

3.3.1 Web GUI – Information box

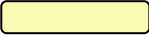
The lower-left corner of each page contains an “information box”. It provides device information: serial number, hardware and firmware version number, IP and MAC address, connection speed, power source and internal device temperature.

3.3.2 Web GUI – Colour-coding scheme

The fields on the web pages use a color-coding scheme to guide the user:

| | | |
|---|-------------|--|
|  | Yellow | Status field: measured value or status |
|  | Light blue | Status field: shows value/status of a setting that can be set at another location |
|  | Light green | Input field |
|  | Orange | Input field, error in setting |
|  | Dark green | Input field; User has changed the setting, but not applied it yet. The field stays dark until settings are applied |
|  | Gray | Input field but setting is disabled |

3.3.3 Web GUI – Tabs

The DTE-3114 web GUI uses a tabbed interface. Clicking a tab will open a page with settings and/or status information. The web interface has the following tabs:

| | |
|---------------------------|---|
| Device Status | The default page for monitoring the operation of the DTE-3114. Displays the main status information including a computed plot of the spectrum at the RF output. |
| IP Status | Displays status information about the settings for each channel and information about the incoming TSolP streams. Per channel three counters maintaining statistics about the IP stream are displayed. Each channel has a clear button for clearing the counters. |
| SMPTE Settings | This tab page lets the user, for each channel, chose between unicast and multicast, select an IP address and port number and enable or disable FEC reconstruction. Note: SMPTE 2022 is the standard specifying methods to encapsulate Transport Packets in IP packets. |
| Modulator Settings | The primary page for controlling the modulation- and RF output parameters. The behavior of the channel-frequency controls depends on the channel-spacing setting: <ul style="list-style-type: none"> • 5/6/7/8MHz – A fixed channel spacing is used. The frequencies of the four channels will be ‘slaved’ to each other with the selected channel spacing; • ‘No fixed channel spacing’ – Each channel frequency can be set independently. However, the four channels should fit within 32MHz. |
| Network Settings | Enables the user to configure the network properties of the DTE-3114: <ul style="list-style-type: none"> • Obtain IP address through DHCP or use a static IP address; • Enable/disable SNMP agent; • Configuration of SNMP agent; • Display identification of the DTE-3114. |

3.3.4 Web GUI – Error handling

When parameters are changed on one of the settings pages, these changes are not immediately propagated to the DTE-3114. Only when the Apply button is pressed, the settings are actually put into operation.

If the settings contain an error, or multiple errors, the Apply button is grayed out. Fields related to the error turn orange. In addition, the SMPTE Settings page and the Modulator Settings page contain a settings-status field that shows a human-readable error message related to the settings error.

The settings-status field can report only one settings error at a time; other errors, if any, are masked. When the error is solved, the next settings error will appear. Only when there is no error anymore, the settings can be applied.

In general the settings error is linked to a setting, or to a combination of settings, on the same web page. However, in exceptional cases the settings-status field shows an error message that is related to illegal settings on another page.

3.4 SNMP

The SNMP interface is intended to be used for automatic control and monitoring of a DTE-3114 by a Network Management System.

To enable SNMP-based management and control, the SNMP agent has to be started via the Network setting page of the web browser. The read and a write community for the SNMP connection can also be configured on this page.

3.4.1 SNMP – MIBs

The DTE-3114 supports three MIBs:

- MIB-II (RFC-1213)
Standard MIB for network management of TCP/IP-based internets.
- DTE-MIB, see Appendix A;
Universal MIB for DekTec DTE products.
- DTE-QAM-MIB, see Appendix B.
Specialized MIB for DekTec networked QAM modulators.

3.4.2 SNMP – Actual and desired settings

The DTE-3114 uses a special mechanism for dealing with erroneous combination of parameters, using “actual” and “desired” settings.

| | |
|-------------------------|--|
| Actual settings | The set of parameters that is currently active. By design, the actual settings are always valid, because invalid parameter values are never propagated to the actual settings. |
| Desired settings | SNMP read and write requests operate on the desired settings. When – after an SNMP write – there are no errors in the desired settings, they will be copied directly to the actual settings and become operational. However, if changing a setting causes a settings error, the desired settings are updated but the actual settings remain unchanged. Only when the desired settings are consistent again, they will be copied to the actual settings. Note: Desired settings will be lost during a power cycle |

It has to be emphasized that SNMP read actions operate on the desired settings. The actual settings cannot be directly observed from SNMP. If the SNMP manager wants to observe the actual settings, he can do so by writing a ‘1’ to object devSynchroniseSettings in the DTE-MIB. This will copy the actual settings back to the desired settings.

An NMS can force a certain parameter set by writing the required values to all MIB objects that represent a writeable parameter. Doing this will not interrupt the operation of channels which had the right settings already.

3.4.3 SNMP – Traps

The DTE-3114 supports two SNMP traps. To become operational, the traps have to be enabled and a destination IP address and trap community must be set.

| | |
|-------------------------|---|
| Temperature trap | Generated if the temperature rises above a given value. The temperature threshold can be set via SNMP in the DTE-MIB. |
| RF level trap | Generated if the difference in dB between the device's target and measured RF level exceeds a given threshold. Under normal circumstances this trap will not occur unless the DTE-3114 is defective. The maximum RF level difference can be set in the DTE-QAMMOD-MIB; this value can safely be left at its default value. |

3.5 Settings errors

To avoid invalid user settings a settings error mechanism in both web interface and SNMP is active.

The tables below provide a list of all settings errors. Note that the settings-status field reports only the first error appearing on the list. When the error is removed, the next settings error, if any, will appear.

Settings errors related to the “SMPTE Settings” webpage and DTE-MIB:

| ID | Settings error | Description / Remarks |
|----|-------------------------|---|
| 1. | IP address is not valid | The selected IP address cannot be used as source address. The valid range for multicast addressing is 224.0.0.0 .. 239.255.255.255. |

| ID | Settings error | Description / Remarks |
|----|---|--|
| 2. | Port is not valid | The selected port number is not valid (1 .. 65535). |
| 3. | IP-to-RF delay is out of range | The valid range is 0 .. 120ms. |
| 4. | Port numbers overlap | If FEC decoding is enabled for a TSolP stream entering the DTE-3114 on port x, then port numbers x+2 and x+4 are reserved for FEC packets and cannot be used by other channels with the same source IP address. |
| 5. | FEC settings are not equal for all channels | If two or more channels refer to the same TSolP stream (same source stream modulated on different frequencies), then the FEC-decoding settings and IP-to-RF delays for these channels must be equal to each other. |
| 6. | <i>Not used</i> | |
| 7. | Modulator settings are not consistent | |

Settings error related to the “Modulator Settings” webpage and DTE-QAM-MIB:

| ID | Settings error | Description / Remarks |
|-----|--|---|
| 1. | Modulation standard is invalid | The modulation standard is not 0 (DVB-C), 1 (J.83 Annex B) or 2 (J.83 Annex C). |
| 2. | QAM mode is invalid | |
| 3. | Symbol rate is out of range | |
| 4. | Interleaver I is out of range | |
| 5. | Interleaver J is out of range | |
| 6. | Frequency is out of range | |
| 7. | Overall spectrum cannot be wider than 32 MHz | The difference between the highest carrier frequency and the lowest carrier frequency may not be greater than 24MHz. |
| 8. | Channel frequencies must increase monotonically | Channel carrier frequencies cannot be entered arbitrarily: The frequency of the first channel must be lower than that of the second channel, etc. |
| 9. | RF level is out of range | The output level, which is the sum of the output levels of the four modulator channels, is outside the valid range. |
| 10. | Modulation standards are not equal for all channels | To satisfy hardware constraints, each channel must operate in the same QAM standard (DVB-C, ...). |
| 11. | QAM modes are not equal for all channels | Idem for QAM mode (64-QAM, ...). |
| 12. | Spectral inversion settings are not equal for all channels | Idem for spectral inversion. |
| 13. | Symbol rates are not equal for all channels | Idem for symbol rate. |
| 14. | Interleaver settings are not equal for all channels | Idem for interleaver settings (J.83 Annex B only). |
| 15. | Combination of interleaver I and | The combination of interleaver parameters I and J is not |

| ID | Settings error | Description / Remarks |
|-----|---|---|
| | J is invalid | according to J.83 Annex B. |
| 16. | RF-level range is too wide | The difference between the largest RF level and the lowest RF level is more than 6dB. |
| 17. | Spectrum overlaps spectrum of another channel | Spectrum overlap causes interference and is not allowed. |
| 18. | SMPTE settings are not consistent | |

3.6 Firmware upgrade

The firmware of the DTE-3114 can be upgraded using the Firmware Upgrade page of the web interface.

First the required DTE-3114 firmware file must be obtained, e.g. from the DekTec website. An upgrade file normally has the extension: *.dte*. Put this file somewhere on a local disk. On the Firmware Upgrade page, use the 'upgrade' button and select the location of the new firmware file. After approving the upgrade by clicking the 'yes' button, the upgrade will start.

The progress of the upgrade can be monitored on the webpage and also on the LCD display of the DTE-3114 device. When the upgrade is complete, the device will reboot automatically. A complete upgrade will take approximately 90 seconds.

Warning: Do not power off the device while an upgrade is in progress.

4. System Configuration

4.1 General

For proper operation of the DTE-3114 a system integrator has to take into account two essential factors:

1. Bitrate of the IP streams
2. IP jitter

Ad 1. A QAM signal has, depending on the selected modulation parameters, a certain bitrate capacity. If the bitrate of the incoming IP stream exceeds this capacity, internal buffer overflows may occur in the DTE-3114 and no sustainable reliable operation is possible.

Ad 2. The network will cause variable delays of the IP packets, leading to “IP jitter”. The amount of jitter depends on the size of the network, and the amount of IP-traffic congestion. The DTE-3114 will have to know the maximum amount of jitter so that it can compensate.

4.2 Managing bitrates

The bitrate of an incoming IP streams may not exceed the “nominal” bitrate of the QAM-modulator channel, which depends on the selected modulation standard, QAM mode, and symbol rate. If the input bitrate is lower than the nominal bitrate, the DTE-3114 will automatically insert null packets into the Transport Stream to achieve the nominal bitrate.

The tables below show the relation between modulation standard, symbol rate, bandwidth and resulting Transport-Stream bitrate for a number of typical symbol rates.

DVB-C

| | Symbol rate (MBd) | Bandwidth (MHz) | Bitrate (Mbps) |
|--------|-------------------|-----------------|----------------|
| 32-QAM | 4.48* | 5.15 | 20.643137 |
| | 6.875 | 7.91 | 31.678922 |
| | 6.89 | 7.92 | 31.748039 |
| | 6.90 | 7.94 | 31.794118 |
| | 6.92 | 7.96 | 31.886275 |
| | 6.95 | 7.99 | 32.024510 |
| 64-QAM | 4.48* | 5.15 | 24.771765 |
| | 6.875 | 7.91 | 38.014706 |
| | 6.89 | 7.92 | 38.097647 |
| | 6.90 | 7.94 | 38.152941 |
| | 6.92 | 7.96 | 38.263529 |
| | 6.95 | 7.99 | 38.429412 |

| | Symbol rate (MBd) | Bandwidth (MHz) | Bitrate (Mbps) |
|---------|-------------------|-----------------|----------------|
| 128-QAM | 4.48* | 5.15 | 28.900392 |
| | 6.875 | 7.91 | 44.350490 |
| | 6.89 | 7.92 | 44.447255 |
| | 6.90 | 7.94 | 44.511765 |
| | 6.92 | 7.96 | 44.640784 |
| | 6.95 | 7.99 | 44.834314 |
| 256-QAM | 4.48* | 5.15 | 33.029020 |
| | 6.875 | 7.91 | 50.686275 |
| | 6.89 | 7.92 | 50.796863 |
| | 6.90 | 7.94 | 50.870588 |
| | 6.92 | 7.96 | 51.018039 |
| | 6.95 | 7.99 | 51.239216 |

* Not a typical DVB-C bitrate. This is the minimum symbol rate that can be handled by the DTE-3114.

ITU-T J.83 Annex B ("QAM-B")

| | Symbol rate (MBd) | Bandwidth (MHz) | Bitrate (Mbps) |
|---------|-------------------|-----------------|----------------|
| 64-QAM | 4.48* | 5.29 | 23.893333 |
| | 5.056941 | 5.97 | 26.970352 |
| 256-QAM | 4.48* | 5.02 | 32.435545 |
| | 5.360537 | 6.00 | 38.810701 |

* Not a typical QAM-B bitrate. This is the minimum symbol rate that can be handled by the DTE-3114.

ITU-T J.83 Annex C ("QAM-C", Japan)

| | Symbol rate (MBd) | Bandwidth (MHz) | Bitrate (Mbps) |
|---------|-------------------|-----------------|----------------|
| 32-QAM | 4.48* | 5.06 | 20.643137 |
| | 5.25 | 5.93 | 24.191176 |
| | 5.30 | 5.99 | 24.421569 |
| 64-QAM | 4.48* | 5.06 | 24.771765 |
| | 5.25 | 5.93 | 29.029412 |
| | 5.30 | 5.99 | 29.305882 |
| 128-QAM | 4.48* | 5.06 | 28.900392 |
| | 5.25 | 5.93 | 33.867647 |
| | 5.30 | 5.99 | 34.190196 |
| 256-QAM | 4.48* | 5.06 | 33.029020 |
| | 5.25 | 5.93 | 38.705882 |
| | 5.30 | 5.99 | 39.074510 |

* Not a typical QAM-C bitrate. This is the minimum symbol rate that can be handled by the DTE-3114.

For proper operation of the DTE-3114, the system integrator must take care that the input bitrate of each incoming Transport Streams is *somewhat below* the nominal bitrate at all times. Due to small frequency deviations between the clocks of the transmitter and the DTE-3114, which are inevitable, a minimum margin of 100ppm must be reserved.

For example, if the DTE-3114 is configured for DVB-C in 256-QAM mode and a symbol rate of 6.875Mbaud, then it follows from the table above that the nominal bit rate is:

$$R_{\text{nominal}} = 50.686275 \text{ MBps}$$

The corresponding maximum allowed input bitrate is:

$$R_{\text{max}} = 50.686275 * (1 - 100e-6) = 50.681206 \text{ Mbps}$$

The DTE-3114 continuously measures the bitrate of the incoming Transport Stream. The system integrator can use this estimate to verify proper operation. The estimated bitrate is shown in the "Device Status" webpage and via SNMP (DTE-MIB: nwRxTsRate).

If the input bitrate is higher than the nominal bitrate, the internal buffers may overflow. This will lead to an increment of RxIpJitterErrorCounter in the MIB (not visible in the web page). The internal buffer overflow may result in a lock error. This will increment nwRxLockErrorCounter (in the MIB and also visible on the IP status webpage). Following a lock error the modulator channel will reset itself and restart, resulting in a short interruption of the output.

4.3 IP jitter

An idealised TSolP transmitter generates IP packets that are evenly spaced: the time between IP packets is constant. When propagating through a network IP packets may incur varying delays caused by network congestion, timing drift and/or route changes in the network. These will manifest itself as jitter in the arrival time of the IP packets, so-called "IP jitter". A non-ideal transmitter adds to the IP jitter.

The DTE-3114 can tolerate a certain amount of jitter by using an internal buffer to smoothen the data rate. The size of this buffer determines the maximum IP jitter that can still be accepted. The buffer is also used for storing IP packets to perform the 2D FEC decoding. This complicates matters, but it is done to minimize the overall delay. The user can configure the total buffer size by setting the IP-to-RF delay on the "SMPTE Settings" webpage or via the nwRxIpToOutputDelay MIB object.

The delay from IP input to RF output (IP-to-RF delay) is the sum of:

- *FEC delay*: The time required to receive a sufficient amount of packets to enable correction of an IP packet in a 2D FEC block. The FEC delay is automatically computed by the DTE-3114 and depends on the used FEC parameters in the incoming IP stream. The FEC delay is set to zero if FEC decoding is disabled.
- *IP jitter tolerance*: The time that the DTE-3114 waits to receive "late" IP packets. Because of this delay the DTE-3114 can tolerate IP jitter up to the indicated value. The IP jitter tolerance will be automatically computed from the configured IP-to-RF delay and the FEC delay.

The DTE-3114 measures the maximum amount of jitter and presents it to the user via the delay factor. The delay factor is the maximum difference, observed at the network input of the DTE-3114, between the actual arrival of a UDP/RTP packet and the ideal arrival of the packet. The delay factor is measured every second.

The delay factor can be used to verify that the measured IP jitter does not exceed the maximum jitter tolerance. If the maximum is exceeded the IP jitter buffer will underflow (increment of

RxlpJitterErrorCounter, not visible in the web page) and will result in lock errors (increment of nwRxLockErrorCounter and visible on the IP status webpage). After a lock error the channel will restart, resulting in a short interruption of the output.

5. Specifications

5.1 Network connection

| | Min | Typ | Max | |
|----------------------------|-----|------------------------------------|-----|-----------------------------|
| Network Port | | | | |
| Standard | | IEEE 802.3af | | Power over Ethernet Mbps |
| Data rate | | 10/100/1000 auto detect | | |
| Connector | | RJ-45 with LEDs | | |
| Power over Ethernet | | | | |
| PoE class | | Class 0 | | |
| Control | | | | |
| Ethernet encapsulation | | IEEE 802.2 SNAP and Ethernet II | | |
| IP version | | IPv4 | | |
| IP-address assignment | | DHCP or static | | |
| Multicast support | | IGMP v2 | | |
| Network management | | SNMP v2c, | | |
| MIBs | | MIB II, DTE-MIB, DTE-QAMMOD-MIB | | |
| Discovery | | WS Discovery | | |

5.2 Transport-Stream input over IP

| | Min | Typ | Max | |
|-------------------------------|-----|---------------------------|----------------|---------------------|
| General | | | | |
| Number of channels | | 4 | | |
| TSolP encapsulation | | UDP, SMPTE 2022-2-2007 | | |
| IP-to-RF delay ⁽¹⁾ | 1 | | 120 | ms (programmable) |
| IP input jitter tolerance | 1 | | 120 | ms (computed) |
| FEC reconstruction delay | | | ⁽²⁾ | ms (computed) |
| UDP | | | | |
| Transport-Packet size | | 188 or 204 | | bytes |
| TS packets / IP packet | 1 | | 7 | No long UDP packets |

| | Min | Typ | Max | |
|------------------------|-------------------|-----|-----|---------------------|
| RTP | | | | |
| FEC | SMPTE 2022-1-2007 | | | |
| Transport-Packet size | 188 or 204 | | | bytes |
| TS packets / IP packet | 1 | | 7 | No long UDP packets |
| FEC size: L | 1 | | 20 | |
| FEC size: D | 4 | | 20 | |
| FEC size: LxD | | | 100 | |

⁽¹⁾ Excludes interleaver delay

⁽²⁾ Depends on input bitrate, FEC matrix size and number of TS packets per IP packet

5.3 RF Outputs

| | Min | Typ | Max | |
|--|----------|-----|-----|-------------------|
| Main RF Port | | | | |
| Connector type | F Female | | | |
| Impedance | 75 | | | Ω |
| Return loss | 14.5 | | | dB (32..1006MHz) |
| Output level ⁽³⁾ | -32 | | -9 | dBm |
| Step size | 0.5 | | | dB |
| Accuracy | | | | ± 1 dB |
| Output level differential ⁽⁴⁾ | -3 | | 3 | dB |
| Spectral purity | 60 | | | dB @ -9dBm output |
| Monitor RF Port | | | | |
| Connector type | F Female | | | |
| Impedance | 75 | | | Ω |
| Return loss | 15 | | | dB (32..1006MHz) |
| Output level ⁽⁵⁾ | -25.5 | | | dBm |
| Accuracy | | | | ± 3 dB |
| RF Frequency | | | | |
| Frequency range | 32 | | | 1006 MHz |
| Channel spacing | 5 | | | 8 MHz |
| Step size | 1 | | | kHz |
| Stability | 5 | | | ppm |
| Accuracy | 5 | | | ppm |
| Phase Noise @ 10kHz | -95 | | | dBc/Hz |

⁽³⁾ Total output level of all four channels combined

⁽⁴⁾ Maximum differential from average output level

⁽⁵⁾ Total output level of all four channels combined, for the case that the channels have identical RF levels

5.4 Modulation

| | Min | Typ | Max | |
|--|--|----------|-----|--|
| QAM-A Standard Constellations | EN 300 429 32/64/128/256-QAM | | | DVB-C |
| QAM-B Standard Constellations Interleaver modes | ITU-T-J.83 Annex B 64/256-QAM All I, J defined in ITU-T-J.83 1997-04, Table B.2 | | | USA |
| QAM-C Standard Constellations | ITU-T-J.83 Annex C 32/64/128/256-QAM | | | Japan |
| Symbol Rate Range ⁽⁶⁾ Resolution MER (equalised) Spectrum flatness (1 channel) Shoulder attenuation | 4.48 | 6.9 1 | 7.0 | MBd Bd dB dB dB @ -9dBm output |

⁽⁶⁾ This symbol-rate range is supported for all QAM standards, including QAM-B

5.5 Other Specifications

| | Min | Typ | Max | |
|--|---|-----|--------------|----------------|
| Power Auxiliary power supply Power consumption | 20 | 24 | 48 8 | V W |
| Temperature Sensor Measurement range Accuracy | -25 -13 | | +100 +212 | °C °F °C |
| Environmental EMC Hazardous substances Flammability Ambient temperature | CE, FCC ⁽⁷⁾ RoHS compliant UL-94 HB ⁽⁸⁾ | | | |
| | 0 +32 | | +35 +95 | °C °F |

| | Min | Typ | Max |
|----------------------|---------------------|-----|-------------------|
| Mechanical | | | |
| Mounting | DIN-rail TS35, TS32 | | |
| Dimensions W x H x D | 34 x 133 x 133 | | mm (no clicker) |
| | 34 x 133 x 155 | | mm (with clicker) |
| Weight | 324 | | g (no clicker) |
| | 340 | | g (with clicker) |

⁽⁷⁾ Pending formal validation

⁽⁸⁾ By design; no formal UL qualification

Appendix A. DTE-MIB

```

DTE-MIB DEFINITIONS ::= BEGIN

IMPORTS MODULE-IDENTITY, OBJECT-TYPE, NOTIFICATION-TYPE, enterprises, IPAddress,
    TimeTicks, Counter32, Integer32, Unsigned32, Counter64
    FROM SNMPv2-SMI
    OBJECT-GROUP, NOTIFICATION-GROUP FROM SNMPv2-CONF;

main MODULE-IDENTITY
    LAST-UPDATED "201302180800Z"
    ORGANIZATION "DekTec Digital Video B.V."
    CONTACT-INFO
        "
        Godelindeweg 4
        1217 HR Hilversum
        The Netherlands
        Phone: +31 35 2030100
        E-mail: info@dektec.com
        "
    DESCRIPTION
        "
        General MIB for DekTec's DTE-31xx product range of Networked DTV Adapters.

        The DTE-MIB consists of three main groups:
        'system' for device-level settings,
        'network' for IP settings, and
        'traps' specifying the alarms.

        A typical DTE-31xx device supports this MIB together with a device-specific
        MIB. The DTE-MIB describes those control and status variables that are
        common to most DTE-31xx devices. The DTE-MIB is therefore designed to be
        independent of the number of supported input and outputs.
        "
    ::= { enterprises 27070 3 1 }

-- DekTec's private enterprise number
dektec OBJECT IDENTIFIER ::= { enterprises 27070 }
dte OBJECT IDENTIFIER ::= { dektec 3 }

-- For compatibility with Interniche mibcomp compiler
DisplayString ::= OCTET STRING
AbsoluteCounter32 ::= Unsigned32

-- The DTE-MIB main groups
system OBJECT IDENTIFIER ::= { main 1 }
network OBJECT IDENTIFIER ::= { main 2 }
traps OBJECT IDENTIFIER ::= { main 3 }
groups OBJECT IDENTIFIER ::= { main 4 }

-- Main group 'system' subgroups
temperature OBJECT IDENTIFIER ::= { system 1 }
device OBJECT IDENTIFIER ::= { system 2 }
snmpTraps OBJECT IDENTIFIER ::= { system 3 }

-- Main group 'network' subgroups
nwrXChannels OBJECT IDENTIFIER ::= { network 1 }
nwtXChannels OBJECT IDENTIFIER ::= { network 2 }

-----
-- Group: system - temperature --
-- --
-- MIB objects related to the internal temperature of the device. --
-----

tmpTemperature OBJECT-TYPE
    SYNTAX Integer32
    MAX-ACCESS read-only
    STATUS current
    DESCRIPTION
        "Internal device temperature in tenths of degrees Celsius"
    ::= { temperature 1 }

tmpAlarmEnable OBJECT-TYPE
    SYNTAX INTEGER {
        disable(0),
        enable(1)
    }
    MAX-ACCESS read-write
    STATUS current
    DESCRIPTION
        "Enable or disable the temperature alarm.

```

```

    0 disable temperature-alarm trap generation
    1 enable temperature-alarm trap generation"
::= { temperature 2 }

tmpAlarmValue OBJECT-TYPE
SYNTAX      Integer32
MAX-ACCESS  read-write
STATUS      current
DESCRIPTION
    "Threshold temperature in tenths of degrees Celsius. If
    the internal device temperature exceeds this threshold,
    trap 'trTemperatureError' is generated (if enabled)."
```

```

-----
-- Group: system - device                                --
-----

devType OBJECT-TYPE
SYNTAX      DisplayString(SIZE(16))
MAX-ACCESS  read-only
STATUS      current
DESCRIPTION
    "Device type number (e.g. 'DTE-3100')."
```

```

::= { device 1 }

devSerialNumber OBJECT-TYPE
SYNTAX      DisplayString(SIZE(13))
MAX-ACCESS  read-only
STATUS      current
DESCRIPTION
    "Unique serial number for this device."
::= { device 2 }

devHardwareRevision OBJECT-TYPE
SYNTAX      Integer32
MAX-ACCESS  read-only
STATUS      current
DESCRIPTION
    "Hardware revision number."
::= { device 3 }

devFirmwareVersion OBJECT-TYPE
SYNTAX      Integer32
MAX-ACCESS  read-only
STATUS      current
DESCRIPTION
    "Firmware version number."
::= { device 4 }

devPowerStatus OBJECT-TYPE
SYNTAX      INTEGER {
                external(0),
                ethernet(1)
            }
MAX-ACCESS  read-only
STATUS      current
DESCRIPTION
    "Indicates which power source is used by the device:
    0 device is powered from an external power-supply
    1 device is powered via network connector (Power over Ethernet)"
::= { device 5 }

devDisplayName OBJECT-TYPE
SYNTAX      DisplayString(SIZE(5))
MAX-ACCESS  read-write
STATUS      current
DESCRIPTION
    "Display name assigned to this device. Devices with a
    LCD display will show this string on their display."
::= { device 6 }

devNetworkLinkSpeed OBJECT-TYPE
SYNTAX      INTEGER {
                speed10Mbps100Mbps(0),
                speed1000Mbps(1)
            }
MAX-ACCESS  read-only
STATUS      current
DESCRIPTION
    "Speed of the network link.
    0 10/100 Mbps
    1 1000 Mbps
"
```

```

 ::= { device 7 }

devWatchdogCounter OBJECT-TYPE
    SYNTAX      Integer32
    MAX-ACCESS  read-only
    STATUS      current
    DESCRIPTION
        "Counter that keeps the number of times the processor is restarted because
         of a watchdog alarm."
 ::= { device 8 }

devPowerCycleCounter OBJECT-TYPE
    SYNTAX      Integer32
    MAX-ACCESS  read-only
    STATUS      current
    DESCRIPTION
        "Counter that keeps the number of power cycles."
 ::= { device 9 }

devSynchroniseSettings OBJECT-TYPE
    SYNTAX      Integer32
    MAX-ACCESS  read-write
    STATUS      current
    DESCRIPTION
        "Writing to this object will synchronise the value of the MIB objects with
         the current run-time settings."
 ::= { device 10 }

devStatus OBJECT-TYPE
    SYNTAX      Integer32
    MAX-ACCESS  read-only
    STATUS      current
    DESCRIPTION
        "Reflects the status of the device:
         0 normal operation
         1 hardware error
         2 channel error
         3 temperature error"
 ::= { device 11 }

devReboot OBJECT-TYPE
    SYNTAX      Integer
    MAX-ACCESS  read-write
    STATUS      current
    DESCRIPTION
        "Reboots the device
         Any write to this address will cause the device to reboot.
         Any read will return 0"
 ::= { device 12 }

-----
-- Group: system - snmpTraps
-----

snmpTrapEnable OBJECT-TYPE
    SYNTAX      INTEGER {
                disable(0),
                enable(1)
            }
    MAX-ACCESS  read-write
    STATUS      current
    DESCRIPTION
        "Enable or disable generation of SNMP traps.
         0 disable trap generation
         1 enable trap generation"
    DEFVAL { disable }
 ::= { snmpTraps 1 }

snmpTrapCommunity OBJECT-TYPE
    SYNTAX      DisplayString(SIZE(20))
    MAX-ACCESS  read-write
    STATUS      current
    DESCRIPTION
        "SNMP trap community."
 ::= { snmpTraps 2 }

snmpTrapDestination OBJECT-TYPE
    SYNTAX      IpAddress
    MAX-ACCESS  read-write
    STATUS      current
    DESCRIPTION
        "Destination IP address for SNMP traps."
 ::= { snmpTraps 3 }

```

```

snmpTrapIpPort OBJECT-TYPE
    SYNTAX      Integer32 (1..65535)
    MAX-ACCESS  read-write
    STATUS      current
    DESCRIPTION
        "Destination IP port for SNMP traps."
    DEFVAL { 162 }
    ::= { snmpTraps 4 }

-----

-- Group: network
--
-- The network group holds the network receive and transmit channels
--
-- Receive channel:
-- Abstraction for a process that receives a transport stream from the
-- IP network, and outputs the transport stream to a 'sink' interface,
-- e.g. an ASI output port.
--
-- Transmit channel:
-- Abstraction for a process that transmits a transport stream to the
-- IP network, with input coming from a 'source' interface, e.g an ASI
-- input port or a DVB-S2 receiver.
-----

-- Group: network - nwRxChannels
-----

nwRxNumberOfChannels OBJECT-TYPE
    SYNTAX      Integer32
    MAX-ACCESS  read-only
    STATUS      current
    DESCRIPTION
        "Number of network receive channels available on this device."
    ::= { nwRxChannels 1 }

nwRxTable OBJECT-TYPE
    SYNTAX      SEQUENCE OF NwRxEntry
    MAX-ACCESS  not-accessible
    STATUS      current
    DESCRIPTION
        "A list of network receive channel entries. The number
         of entries is given by the value of 'nwRxNumberOfChannels'."
    ::= { nwRxChannels 2 }

nwRxEntry OBJECT-TYPE
    SYNTAX      NwRxEntry
    MAX-ACCESS  not-accessible
    STATUS      current
    DESCRIPTION
        "A network receive channel entry containing objects
         with control and status data."
    INDEX { nwRxIndex }
    ::= { nwRxTable 1 }

NwRxEntry ::= SEQUENCE {
    nwRxIndex          Integer32,
    nwRxSinkType       INTEGER,
    nwRxSinkIndex      Integer32,
    nwRxChannelEnable  INTEGER,
    nwRxAddressingMethod  INTEGER,
    nwRxIpPort         Integer32,
    nwRxMulticastAddress  IpAddress,
    nwRxSourceSpecificMulti  IpAddress,
    nwRxFecEnable      INTEGER,
    nwRxIpToOutputDelay  Integer32,
    nwRxOperationalStatus  INTEGER,
    nwRxProtocol       INTEGER,
    nwRxNumberOfTpPerIp  Integer32,
    nwRxFecNumberOfRows  Integer32,
    nwRxFecNumberOfColumns  Integer32,
    nwRxIpLostBeforeFec  Counter64,
    nwRxIpLostAfterFec   Counter64,
    nwRxIpJitterTolerance  Integer32,
    nwRxFecDelay        Integer32,
    nwRxTsPacketSize   INTEGER,
    nwRxTsRate          Integer32,
    nwRxTsPcrPresent    INTEGER,
    nwRxTsRateChangeCounter  Counter64,
    nwRxTsRateEstimationMode  INTEGER,
    --   nwRxTsManualRate      Integer32,
    --   nwRxTsManualControlRange  Integer32,
    nwRxIpJitterErrorCounter  Counter64,
    nwRxLockErrorCounter    Counter64,

```

```

    nwRxDelayFactor          Integer32,
    nwRxSettingsStatus      Integer32
}

nwRxIndex OBJECT-TYPE
SYNTAX      Integer32(1..65535)
MAX-ACCESS  read-only
STATUS      current
DESCRIPTION
    "A unique value identifying this network receive channel.
    The value ranges between 1 and the value of 'nwRxNumberOfChannels'."
DEFVAL { 1 }
 ::= { nwRxEntry 1 }

nwRxSinkType OBJECT-TYPE
SYNTAX      INTEGER {
                asi(1),
                sdi(2),
                qam(3)
            }
MAX-ACCESS  read-only
STATUS      current
DESCRIPTION
    "Identifies the type of interface connected to the output of this network
    receive channel:
    1 ASI output (see 'DTE-ASI-MIB')
    2 SDI output (see 'DTE-SDI-MIB')
    3 QAM modulator output (see 'DTE-QAMMOD-MIB')"
 ::= { nwRxEntry 2 }

nwRxSinkIndex OBJECT-TYPE
SYNTAX      Integer32
MAX-ACCESS  read-only
STATUS      current
DESCRIPTION
    "Table index of the entry describing the associated output (sink) interface.
    This entry can be found in the MIB associated with the output type
    defined by 'nwRxSinkType'."
 ::= { nwRxEntry 3 }

nwRxChannelEnable OBJECT-TYPE
SYNTAX      INTEGER {
                disable(0),
                enable(1)
            }
MAX-ACCESS  read-write
STATUS      current
DESCRIPTION
    "Enable or disable this channel.
    0 disable the channel
    1 enable the channel"
DEFVAL { disable }
 ::= { nwRxEntry 4 }

nwRxAddressingMethod OBJECT-TYPE
SYNTAX      INTEGER {
                unicast(0),
                anySourceMulticast(1),
                sourceSpecificMulticast(2)
            }
MAX-ACCESS  read-write
STATUS      current
DESCRIPTION
    "IP addressing method.
    0 unicast reception
    1 any-source-multicast (IGMPv2) reception
    2 source specific multicast (IGMPv3) reception"
 ::= { nwRxEntry 5 }

nwRxIpPort OBJECT-TYPE
SYNTAX      Integer32 (1..65535)
MAX-ACCESS  read-write
STATUS      current
DESCRIPTION
    "Incoming IP port. The device will listen for an IP stream on this port."
 ::= { nwRxEntry 6 }

nwRxMulticastAddress OBJECT-TYPE
SYNTAX      IpAddress
MAX-ACCESS  read-write
STATUS      current
DESCRIPTION
    "Specifies the IP address of the multicast group to

```

```

    join. If the addressing method is unicast this field
    is ignored."
    ::= { nWRxEntry 7 }

nWRxSourceSpecificMulti OBJECT-TYPE
    SYNTAX      IPAddress
    MAX-ACCESS  read-write
    STATUS      current
    DESCRIPTION
        "Specifies the source IP address used in the source-
        specific-multicast join. If the addressing method is
        unicast or any-source-multicast this field is ignored."
    ::= { nWRxEntry 8 }

nWRxFecEnable OBJECT-TYPE
    SYNTAX      INTEGER {
                disable(0),
                enable(1)
            }
    MAX-ACCESS  read-write
    STATUS      current
    DESCRIPTION
        "Enable or disable FEC reconstruction.
         0 disable FEC reconstruction
         1 enable FEC reconstruction"
    ::= { nWRxEntry 9 }

nWRxIpToOutputDelay OBJECT-TYPE
    SYNTAX      Integer32
    MAX-ACCESS  read-write
    STATUS      current
    DESCRIPTION
        "The desired delay in ms between the reception of an IP
        packet and the data leaving the channel.
        The delay is the sum of the FEC delay and IP jitter tolerance,
        see 'nWRxFecDelay' & 'nWRxIpJitterTolerance'."
    ::= { nWRxEntry 10 }

nWRxOperationalStatus OBJECT-TYPE
    SYNTAX      INTEGER {
                ok(0),
                disabled(1),
                processingError(2),
                settingsError(3),
                noInput(4)
            }
    MAX-ACCESS  read-only
    STATUS      current
    DESCRIPTION
        "Current operational status of the channel.
         0 channel is enabled and there are no problems
         1 channel has been disabled
         2 there is a problem with the processing of the
           received IP stream
         3 there are problems with the settings
         4 no input"
    ::= { nWRxEntry 11 }

nWRxProtocol OBJECT-TYPE
    SYNTAX      INTEGER {
                udp(0),
                rtp(1)
            }
    MAX-ACCESS  read-only
    STATUS      current
    DESCRIPTION
        "IP protocol used by the incoming IP stream.
         0 receiving a UDP stream
         1 receiving an RTP stream"
    ::= { nWRxEntry 12 }

nWRxNumberOfTpPerIp OBJECT-TYPE
    SYNTAX      Integer32 (0..7)
    MAX-ACCESS  read-only
    STATUS      current
    DESCRIPTION
        "Number of transport packets per IP packet. A value of 0
        means that this MIB object is irrelevant, e.g. for SDI-over-IP"
    ::= { nWRxEntry 13 }

nWRxFecNumberOfRows OBJECT-TYPE
    SYNTAX      Integer32 (0..20)
    MAX-ACCESS  read-only
    STATUS      current

```

```

DESCRIPTION
  "Number of FEC rows."
  ::= { nwRxEntry 14 }

nwRxFecNumberOfColumns OBJECT-TYPE
  SYNTAX      Integer32 (0..20)
  MAX-ACCESS  read-only
  STATUS      current
  DESCRIPTION
    "Number of FEC columns."
    ::= { nwRxEntry 15 }

nwRxIpLostBeforeFec OBJECT-TYPE
  SYNTAX      Counter64
  MAX-ACCESS  read-only
  STATUS      current
  DESCRIPTION
    "Number of packets lost before FEC reconstruction."
    ::= { nwRxEntry 16 }

nwRxIpLostAfterFec OBJECT-TYPE
  SYNTAX      Counter64
  MAX-ACCESS  read-only
  STATUS      current
  DESCRIPTION
    "Number of packets lost after FEC reconstruction."
    ::= { nwRxEntry 17 }

nwRxIpJitterTolerance OBJECT-TYPE
  SYNTAX      Integer32
  MAX-ACCESS  read-only
  STATUS      current
  DESCRIPTION
    "The time in ms that the channel waits to receive
    'late' IP packets. Because of this delay the channel
    can tolerate IP jitter up to the indicated value."
    ::= { nwRxEntry 18 }

nwRxFecDelay OBJECT-TYPE
  SYNTAX      Integer32
  MAX-ACCESS  read-only
  STATUS      current
  DESCRIPTION
    "The time in ms required to receive a sufficient number of packets
    to enable correction of an IP packet in a 2D FEC block."
    ::= { nwRxEntry 19 }

nwRxTsPacketSize OBJECT-TYPE
  SYNTAX      INTEGER {
    bytes188(0),
    bytes204(1)
  }
  MAX-ACCESS  read-only
  STATUS      current
  DESCRIPTION
    "Size of the MPEG-2 packets in the received transport stream.
    0 188 bytes
    1 204 bytes"
    ::= { nwRxEntry 20 }

nwRxTsRate OBJECT-TYPE
  SYNTAX      Integer32
  MAX-ACCESS  read-only
  STATUS      current
  DESCRIPTION
    "Estimated bitrate of the transport stream reconstructed for this channel
    at 188-byte per transport packet."
    ::= { nwRxEntry 21 }

nwRxTsPcrPresent OBJECT-TYPE
  SYNTAX      INTEGER {
    noPcrs(0),
    reliablePcrs(1),
    unreliablePcrs(2)
  }
  MAX-ACCESS  read-only
  STATUS      current
  DESCRIPTION
    "PCRs in the incoming transport stream are present or absent.
    0 no pcrs present
    1 reliable pcrs present
    2 unreliable pcrs present"
    ::= { nwRxEntry 22 }

```



```

nwRxTsRateChangeCounter OBJECT-TYPE
    SYNTAX      Counter64
    MAX-ACCESS  read-only
    STATUS      current
    DESCRIPTION
        "Counter that keeps the number of bitrate changes detected on this channel.
        During normal operation this counter should remain constant."
    ::= { nwRxEntry 23 }

nwRxTsRateEstimationMode OBJECT-TYPE
    SYNTAX      INTEGER {
        auto(0),
        autoIgnorePcrs(1),
        delay(2),
        off(3)
    }
    MAX-ACCESS  read-write
    STATUS      current
    DESCRIPTION
        "Mode used to estimate the transport-stream bitrate.
        0 auto
        1 ignore pcrs
        2 fixed delay
        3 off"
    ::= { nwRxEntry 24 }

--nwRxTsManualRate OBJECT-TYPE
--    SYNTAX      Integer32
--    MAX-ACCESS  read-write
--    STATUS      current
--    DESCRIPTION
--        "User-specified rate of the received transport stream. Used if
--        nwRxTsRateEstimationMode is set to 'manual'."
--    ::= { nwRxEntry 25 }

--nwRxTsManualControlRange OBJECT-TYPE
--    SYNTAX      Integer32
--    MAX-ACCESS  read-write
--    STATUS      current
--    DESCRIPTION
--        "Control range in ppm."
--    ::= { nwRxEntry 26 }

nwRxIpJitterErrorCounter OBJECT-TYPE
    SYNTAX      Counter64
    MAX-ACCESS  read-only
    STATUS      current
    DESCRIPTION
        "Counter that keeps the number of IP jitter errors for this channel.
        A jitter error may occur when an incoming IP packet has a jitter that
        exceeds 'nwRxIpJitterTolerance'. During normal operation this counter
        should remain constant."
    ::= { nwRxEntry 27 }

nwRxLockErrorCounter OBJECT-TYPE
    SYNTAX      Counter64
    MAX-ACCESS  read-only
    STATUS      current
    DESCRIPTION
        "Counter that keeps the number of channel restarts. A channel is restarted
        only under adverse circumstances, like large jitter of IP packets in
        combination with packet loss. A channel restart causes a signal interruption
        for this channel of about 1 second. During normal operation this counter
        should remain constant."
    ::= { nwRxEntry 28 }

nwRxDelayFactor OBJECT-TYPE
    SYNTAX      Integer32
    MAX-ACCESS  read-only
    STATUS      current
    DESCRIPTION
        "The channel's delay factor in us. Delay factor is a measure of the maximum
        jitter on the IP packets received for this channel."
    ::= { nwRxEntry 29 }

nwRxSettingsStatus OBJECT-TYPE
    SYNTAX      Integer32
    MAX-ACCESS  read-only
    STATUS      current
    DESCRIPTION
        "Channel status. The status is either 'ok' or an error code.
        If multiple errors are active, the status code with the lowest value is
        reported. When the error condition is resolved, but another error is
        still present, then the next error code will appear."

```

```

List of status codes:
0 - Ok
1 - IP Address is not valid
2 - Port is not valid
3 - IP-to-RF delay is out of range
4 - Port numbers overlap
5 - FEC settings are not equal for all channels
6 - Rate Estimation settings are not equal for all channels
7 - Modulator settings are not consistent
8 - IP-to-RF delay are not equal for all channels"
::= { nwRxEntry 30 }

```

```

-----
-- Group: network - nwTxChannels --
-----
nwTxNumberOfChannels OBJECT-TYPE
    SYNTAX      Integer32
    MAX-ACCESS  read-only
    STATUS      current
    DESCRIPTION
        "Number of network transmit channels available on this device."
    ::= { nwTxChannels 1 }

nwTxTable OBJECT-TYPE
    SYNTAX      SEQUENCE OF NwTxEntry
    MAX-ACCESS  not-accessible
    STATUS      current
    DESCRIPTION
        "A list of network transmit channel entries. The number
         of entries is given by the value of 'nwTxNumberOfChannels'."
    ::= { nwTxChannels 2 }

nwTxEntry OBJECT-TYPE
    SYNTAX      NwTxEntry
    MAX-ACCESS  not-accessible
    STATUS      current
    DESCRIPTION
        "A network transmit channel entry containing objects
         with control and status data."
    INDEX { nwTxIndex }
    ::= { nwTxTable 1 }

NwTxEntry ::= SEQUENCE {
    nwTxIndex          Integer32,
    nwTxSourceType     INTEGER,
    nwTxSourceIndex    Integer32,
    nwTxChannelEnable  INTEGER,
    nwTxIpAddress      IpAddress,
    nwTxIpPort         Integer32,
    nwTxTimeToLive     Integer32,
    nwTxProtocol        INTEGER,
    nwTxNumberOfTpPerIp Integer32,
    nwTxFecEnable       INTEGER,
    nwTxFecNumberOfRows Integer32,
    nwTxFecNumberOfColumns Integer32,
    nwTxIpAddressStatus INTEGER,
    nwTxFecDelay        Integer32,
    nwTxTsPacketSize   Integer32,
    nwTxSettingsStatus Integer32,
    nwTxTypeOfService  Integer32
}

nwTxIndex OBJECT-TYPE
    SYNTAX      Integer32(1..65535)
    MAX-ACCESS  read-only
    STATUS      current
    DESCRIPTION
        "A unique value identifying this network transmit channel.
         The value ranges between 1 and the value of 'nwTxNumberOfChannels'."
    DEFVAL { 1 }
    ::= { nwTxEntry 1 }

nwTxSourceType OBJECT-TYPE
    SYNTAX      INTEGER {
                asi(1),
                sdi(2)
                }
    MAX-ACCESS  read-only
    STATUS      current
    DESCRIPTION
        "Identifies the type of interface connected to the input of this network
         transmit channel:
         1 ASI input (see 'DTE-ASI-MIB')
         2 SDI input (see 'DTE-SDI-MIB')"

```

```

 ::= { nwTxEntry 2 }

nwTxSourceIndex OBJECT-TYPE
    SYNTAX      Integer32
    MAX-ACCESS  read-only
    STATUS      current
    DESCRIPTION
        "Table index of the entry describing the associated input (source) interface.
         This entry can be found in MIB associated with the input type
         defined by 'nwTxSinkType'."
    ::= { nwTxEntry 3 }

nwTxChannelEnable OBJECT-TYPE
    SYNTAX      INTEGER {
                    disable(0),
                    enable(1)
                }
    MAX-ACCESS  read-write
    STATUS      current
    DESCRIPTION
        "Enable or disable this channel.
         0 disable the channel
         1 enable the channel"
    DEFVAL { disable }
    ::= { nwTxEntry 4 }

nwTxIpAddress OBJECT-TYPE
    SYNTAX      IpAddress
    MAX-ACCESS  read-write
    STATUS      current
    DESCRIPTION
        "Destination IP address. The generated IP stream will be sent to this IP address."
    ::= { nwTxEntry 5 }

nwTxIpPort OBJECT-TYPE
    SYNTAX      Integer32 (1..65535)
    MAX-ACCESS  read-write
    STATUS      current
    DESCRIPTION
        "Destination IP port. The generated IP stream will be sent to this IP port."
    ::= { nwTxEntry 6 }

nwTxTimeToLive OBJECT-TYPE
    SYNTAX      Integer32 (0..255)
    MAX-ACCESS  read-write
    STATUS      current
    DESCRIPTION
        "Time to live. The generated IP packets will use the
         TTL specified by this value."
    ::= { nwTxEntry 7 }

nwTxProtocol OBJECT-TYPE
    SYNTAX      INTEGER {
                    udp(0),
                    rtp(1)
                }
    MAX-ACCESS  read-write
    STATUS      current
    DESCRIPTION
        "IP protocol used for generated IP packets.
         0 generate UDP packets
         1 generate RTP packets"
    ::= { nwTxEntry 8 }

nwTxNumberOfTpPerIp OBJECT-TYPE
    SYNTAX      Integer32 (0..7)
    MAX-ACCESS  read-write
    STATUS      current
    DESCRIPTION
        "Number of transport packets per IP packet. A value of 0
         means that this MIB object is irrelevant, e.g. for SDI-over-IP"
    ::= { nwTxEntry 9 }

nwTxFecEnable OBJECT-TYPE
    SYNTAX      INTEGER {
                    disable(0),
                    enable(1)
                }
    MAX-ACCESS  read-write
    STATUS      current
    DESCRIPTION
        "Enable or disable FEC generation.
         0 do not generate a FEC stream
         1 generate a FEC stream (only if 'nwTxProtocol' is set to RTP)"

```

```

 ::= { nwTxEntry 10 }

nwTxFecNumberOfRows OBJECT-TYPE
    SYNTAX      Integer32 (0..20)
    MAX-ACCESS  read-write
    STATUS      current
    DESCRIPTION
        "Number of FEC rows to generate."
 ::= { nwTxEntry 11 }

nwTxFecNumberOfColumns OBJECT-TYPE
    SYNTAX      Integer32 (0..20)
    MAX-ACCESS  read-write
    STATUS      current
    DESCRIPTION
        "Number of FEC columns to generate."
 ::= { nwTxEntry 12 }

nwTxIpAddressStatus OBJECT-TYPE
    SYNTAX      INTEGER {
        ok(0),
        error(1)
    }
    MAX-ACCESS  read-only
    STATUS      current
    DESCRIPTION
        "Destination IP-address resolve status.
         0 destination IP address has been resolved
         1 failed to resolve destination IP address"
 ::= { nwTxEntry 13 }

nwTxFecDelay OBJECT-TYPE
    SYNTAX      Integer32
    MAX-ACCESS  read-only
    STATUS      current
    DESCRIPTION
        "The nominal time in ms required to receive a sufficient number of packets
         to enable correction of an IP packet in a 2D FEC block."
 ::= { nwTxEntry 14 }

nwTxTsPacketSize OBJECT-TYPE
    SYNTAX      Integer32
    MAX-ACCESS  read-only
    STATUS      current
    DESCRIPTION
        "Size of the MPEG-2 packets in the transmitted transport stream."
 ::= { nwTxEntry 15 }

nwTxSettingsStatus OBJECT-TYPE
    SYNTAX      Integer32
    MAX-ACCESS  read-only
    STATUS      current
    DESCRIPTION
        "Channel status. The status is either 'ok' or an error code.
         If multiple errors are active, the status code with the lowest value is
         reported. When the error condition is resolved, but another error is
         still present, then the corresponding error code will appear."
 ::= { nwTxEntry 16 }

nwTxTypeOfService OBJECT-TYPE
    SYNTAX      Integer32 (0..255)
    MAX-ACCESS  read-write
    STATUS      current
    DESCRIPTION
        "Type Of Service. The generated IP packets will use the
         TOS specified by this value."
 ::= { nwTxEntry 17 }

-----
-- DTE Alarm Traps                                --
-----

trTemperatureError NOTIFICATION-TYPE
    OBJECTS { tmpTemperature }
    STATUS      current
    DESCRIPTION
        "Temperature error. The temperature exceeded the
         threshold value set in 'tmpAlarmValue'"
 ::= { traps 1 }

-----
-- Object Groups                                --
-----

```

```

devTemperatureGroup OBJECT-GROUP
  OBJECTS { tmpTemperature,
            tmpAlarmEnable,
            tmpAlarmValue }
  STATUS current
  DESCRIPTION
    "A collection of objects providing temperature information."
  ::= { groups 1 }

devSystemGroup OBJECT-GROUP
  OBJECTS { devType,
            devSerialNumber,
            devHardwareRevision,
            devFirmwareVersion,
            devPowerStatus,
            devDisplayName,
            devNetworkLinkSpeed,
            devWatchdogCounter,
            devPowerCycleCounter,
            devSynchroniseSettings,
            devStatus }
  STATUS current
  DESCRIPTION
    "A collection of objects providing system information."
  ::= { groups 2 }

devSnmpTrapGroup OBJECT-GROUP
  OBJECTS { snmpTrapEnable,
            snmpTrapCommunity,
            snmpTrapDestination,
            snmpTrapIpPort }
  STATUS current
  DESCRIPTION
    "A collection of objects providing trap information."
  ::= { groups 3 }

devnwrXChannelsGroup OBJECT-GROUP
  OBJECTS { nwrXNumberOfChannels,
            nwrXIndex,
            nwrXSinkIndex,
            nwrXSinkType,
            nwrXChannelEnable,
            nwrXAddressingMethod,
            nwrXIpPort,
            nwrXMulticastAddress,
            nwrXSourceSpecificMulti,
            nwrXFecEnable,
            nwrXIpToOutputDelay,
            nwrXOperationalStatus,
            nwrXProtocol,
            nwrXNumberOfTpPerIp,
            nwrXFecNumberOfRows,
            nwrXFecNumberOfColumns,
            nwrXIpLostBeforeFec,
            nwrXIpLostAfterFec,
            nwrXIpJitterTolerance,
            nwrXFecDelay,
            nwrXTsPacketSize,
            nwrXTsRate,
            nwrXTsPcrPresent,
            nwrXTsRateChangeCounter,
            nwrXTsRateEstimationMode,
            nwrXTsManualRate,
            nwrXTsManualControlRange,
            nwrXIpJitterErrorCounter,
            nwrXLockErrorCounter,
            nwrXDelayFactor,
            nwrXSettingsStatus
          }
  STATUS current
  DESCRIPTION
    "A collection of objects providing network receive information."
  ::= { groups 4 }

devnwrTxChannelsGroup OBJECT-GROUP
  OBJECTS { nwrTxNumberOfChannels,
            nwrTxIndex,
            nwrTxSourceType,
            nwrTxSourceIndex,
            nwrTxChannelEnable,
            nwrTxIpAddress,
            nwrTxIpPort,

```

```

        nwTxTimeToLive,
        nwTxProtocol,
        nwTxNumberOfTpPerIp,
        nwTxFecEnable,
        nwTxFecNumberOfRows,
        nwTxFecNumberOfColumns,
        nwTxIpAddressStatus,
        nwTxFecDelay,
        nwTxTsPacketSize,
        nwTxSettingsStatus,
        nwTxTypeOfService
    }
    STATUS current
    DESCRIPTION
        "A collection of objects providing network transmit information."
    ::= { groups 5 }

devAlarmTrapGroup NOTIFICATION-GROUP
    NOTIFICATIONS { trTemperatureError
    }
    STATUS current
    DESCRIPTION
        "A collection of objects providing alarm trap information."
    ::= { groups 6 }

END

```

Appendix B. DTE-QAM-MIB

```

DTE-QAMMOD-MIB DEFINITIONS ::= BEGIN

IMPORTS MODULE-IDENTITY, OBJECT-TYPE, NOTIFICATION-TYPE, enterprises, IpAddress, TimeTicks, Counter32, Integer32,
Unsigned32, Counter64
        FROM SNMPv2-SMI
        OBJECT-GROUP, NOTIFICATION-GROUP FROM SNMPv2-CONF;

qammod MODULE-IDENTITY
    LAST-UPDATED "201302180800Z"
    ORGANIZATION "DekTec Digital Video B.V."
    CONTACT-INFO
        "
        Godelindeweg 4
        1217 HR Hilversum
        The Netherlands
        Phone: +31 35 2030100
        E-mail: info@dektec.com
        "
    DESCRIPTION
        "
        Device-specific MIB for QAM modulators in DekTec's DTE-31xx
        product range of Networked DTV Adapters.
        "
 ::= { enterprises 27070 3 3 }

-- Dektec's private enterprise number
dektec OBJECT IDENTIFIER ::= { enterprises 27070 }
dte OBJECT IDENTIFIER ::= { dektec 3 }

-- For compatibility with Interniche mibcomp compiler
DisplayString ::= OCTET STRING
AbsoluteCounter32 ::= Unsigned32

-- The DTE-QAMMOD-MIB main groups
alarms OBJECT IDENTIFIER ::= { qammod 1 }
outputs OBJECT IDENTIFIER ::= { qammod 2 }
traps OBJECT IDENTIFIER ::= { qammod 3 }
groups OBJECT IDENTIFIER ::= { qammod 4 }

-----
-- Group: alarms --
-----

almRfAlarmValue OBJECT-TYPE
    SYNTAX Integer32
    MAX-ACCESS read-write
    STATUS current
    DESCRIPTION
        "Maximum difference in dB between the device's target and measured
        RF level (in tenths of dB)."
```

```

 ::= { alarms 1 }

almRfAlarmEnable OBJECT-TYPE
    SYNTAX INTEGER {
        disable(0),
        enable(1)
    }
    MAX-ACCESS read-write
    STATUS current
    DESCRIPTION
        "Enable or disable monitoring of the level of the RF output and generation
        of the corresponding log and trap. The target RF level is the sum of the
        RF levels programmed for each individual channel. If 'outRfAlarmEnable'
        is set to 'enable', trap 'trRfLevelError' is generated when the
        difference between the target RF level and the measured RF level exceeds
        the threshold set in 'almRfAlarmValue'."
        0 disable Rf alarm
        1 enable Rf alarm"
 ::= { alarms 2 }

-----
-- Group: outputs --
--
-- MIB objects related to Qam modulator output. --
-----

outNumberOfOutputs OBJECT-TYPE
    SYNTAX Integer32
    MAX-ACCESS read-only
```

```

STATUS      current
DESCRIPTION
"Number of QAM-modulator channels available on this device."
::= { outputs 1 }

outTable OBJECT-TYPE
SYNTAX      SEQUENCE OF OutEntry
MAX-ACCESS  not-accessible
STATUS      current
DESCRIPTION
"A list of QAM-modulator channel entries. The number of entries
is given by the value of 'outNumberOfOutputs'"
::= { outputs 2 }

outEntry OBJECT-TYPE
SYNTAX      OutEntry
MAX-ACCESS  not-accessible
STATUS      current
DESCRIPTION
"A QAM-modulator entry containing objects with control and
status data for a particular QAM-modulator channel."
INDEX { outIndex }
::= { outTable 1 }

OutEntry ::= SEQUENCE {
    outIndex          Integer32,
    outNwRxIndex      Integer32,
    outPhysicalPort   Integer32,
    outFrequency       Integer32,
    outSymbolRate      Integer32,
    outModulationStandard  INTEGER,
    outQamMode         INTEGER,
    outSpectralInversion  INTEGER,
    outInterleaverI     Integer32,
    outInterleaverJ     Integer32,
    outRfLevel         Integer32,
    outSettingsStatus  Integer32
}

outIndex OBJECT-TYPE
SYNTAX      Integer32(1..65535)
MAX-ACCESS  read-only
STATUS      current
DESCRIPTION
"A unique index value for each QAM-modulator channel. The index value
ranges between 1 and the value of 'outNumberOfOutputs'."
DEFVAL { 1 }
::= { outEntry 1 }

outNwRxIndex OBJECT-TYPE
SYNTAX      Integer32
MAX-ACCESS  read-only
STATUS      current
DESCRIPTION
"Table index of the entry for the associated network receive channel.
This entry can be found in the 'nwRxTable' table of the 'DTE-MIB'."
DEFVAL { 1 }
::= { outEntry 2 }

outPhysicalPort OBJECT-TYPE
SYNTAX      Integer32
MAX-ACCESS  read-only
STATUS      current
DESCRIPTION
"Physical port number of QAM-modulator output."
DEFVAL { 1 }
::= { outEntry 3 }

outFrequency OBJECT-TYPE
SYNTAX      Integer32(40000000..1000000000)
MAX-ACCESS  read-write
STATUS      current
DESCRIPTION
"The center frequency of this channel in Hz."
::= { outEntry 4 }

outSymbolRate OBJECT-TYPE
SYNTAX      Integer32(1..65535)
MAX-ACCESS  read-write
STATUS      current
DESCRIPTION
"The symbol rate of this channel in Baud."
::= { outEntry 5 }

```



```

outModulationStandard OBJECT-TYPE
SYNTAX      INTEGER {
                dvbc(0),
                j83AnnexB(1),
                j83AnnexC(2)
            }
MAX-ACCESS  read-write
STATUS      current
DESCRIPTION
    "Modulation standard used for this channel.
     0 dvb-c (j83-annex-a)
     1 j83-annex-b
     2 j83-annex-c"
 ::= { outEntry 6 }

outQamMode OBJECT-TYPE
SYNTAX      INTEGER {
                qam32(5),
                qam64(6),
                qam128(7),
                qam256(8)
            }
MAX-ACCESS  read-write
STATUS      current
DESCRIPTION
    "QAM mode (number of constellation points) used by this channel.
     5 32-QAM
     6 64-QAM
     7 128-QAM
     8 256-QAM"
 ::= { outEntry 7 }

outSpectralInversion OBJECT-TYPE
SYNTAX      INTEGER {
                disable(0),
                enable(1)
            }
MAX-ACCESS  read-write
STATUS      current
DESCRIPTION
    "Enable or disable spectral inversion.
     0 disable spectral inversion
     1 enable spectral inversion
    "
DEFVAL { disable }
 ::= { outEntry 8 }

outInterleaverI OBJECT-TYPE
SYNTAX      Integer32
MAX-ACCESS  read-write
STATUS      current
DESCRIPTION
    "If the modulation standard is j83-annex-b, this settings specifies
     interleaver parameter I."
 ::= { outEntry 9 }

outInterleaverJ OBJECT-TYPE
SYNTAX      Integer32
MAX-ACCESS  read-write
STATUS      current
DESCRIPTION
    "If the modulation standard is j83-annex-b, this settings specifies
     interleaver parameter J."
 ::= { outEntry 10 }

outRfLevel OBJECT-TYPE
SYNTAX      Integer32
MAX-ACCESS  read-write
STATUS      current
DESCRIPTION
    "The desired RF output level in tenths dBmW for this channel."
 ::= { outEntry 11 }

outSettingsStatus OBJECT-TYPE
SYNTAX      Integer32
MAX-ACCESS  read-only
STATUS      current
DESCRIPTION
    "Modulator Channel status. The status is either 'ok' or an error code.
     If multiple errors are active, the status code with the lowest value
     is reported. When the error condition is resolved, but another error
     is still present, then the corresponding error code will appear. See
     Error Settings table."

```

```
List of status codes:
1 - Modulation standard is invalid
2 - QAM mode is invalid
3 - Symbol rate is out of range
4 - Interleaver I is out of range
5 - Interleaver J is out of range
6 - Frequency is out of range
7 - Overall spectrum cannot be wider than 32 Mhz
8 - Channel frequencies must increase monotonically
9 - RF level is out of range
10- Modulation standards are not equal for all channels
11- QAM modes are not equal for all channels
12- Spectral inversion settings are not equal for all channels
13- Symbol rates are not equal for all channels
14- Interleaver settings are not equal for all channels
15- Combination of interleaver I and J is invalid
16- RF-level range is too wide
17- Spectrum overlaps spectrum of another channel
18- SMPTE settings are not consistent"
::= { outEntry 12 }
```

```
-----
-- DTE Alarm Traps --
-----

trRfLevelError NOTIFICATION-TYPE
OBJECTS { almRfAlarmValue }
STATUS current
DESCRIPTION
"RF output level error. The difference between the device's target
RF level (the sum of channel RF levels) and the measured RF level
exceeds 'almRfAlarmValue'."
::= { traps 1 }

-----
-- Object Groups --
-----

devAlarmGroup OBJECT-GROUP
OBJECTS { almRfAlarmValue,
          almRfAlarmEnable }
STATUS current
DESCRIPTION
"A collection of objects providing RF alarm information."
::= { groups 1 }

devOutputGroup OBJECT-GROUP
OBJECTS { outNumberOfOutputs,
          outIndex,
          outNRxIndex,
          outPhysicalPort,
          outFrequency,
          outSymbolRate,
          outModulationStandard,
          outQamMode,
          outSpectralInversion,
          outInterleaverI,
          outInterleaverJ,
          outRfLevel,
          outSettingsStatus
        }
STATUS current
DESCRIPTION
"A collection of objects providing RF output information."
::= { groups 2 }

devAlarmTrapGroup NOTIFICATION-GROUP
NOTIFICATIONS { trRfLevelError
               }
STATUS current
DESCRIPTION
"A collection of objects providing alarm trap information."
::= { groups 3 }

-----
-- END --
-----
END
```